

Artikel Nr.	P [kW]	Pges [kW]	Volumenstrom V [m3/h]	Gasanschluß [Zoll]	Länge Verbrauchsleitung [m] delta p=0.6mBar
GNAA	1x7,5	7,5	0.79	1/2"	6

Verwendungsbereich 410x550x590	Toleranz nach DIN ISO 2768-mK	Oberflächen DIN ISO 1302	Maßstab: 1:8 Werkstoff 1.4301	Gewicht: 57.97 kg
Name	Datum	<b>Gas Wassergrill PASADENA</b>		
Bearb. M.B.	15.07.2020			
<b>HEIDEBRENNER</b>		<b>GNAA</b>		A3

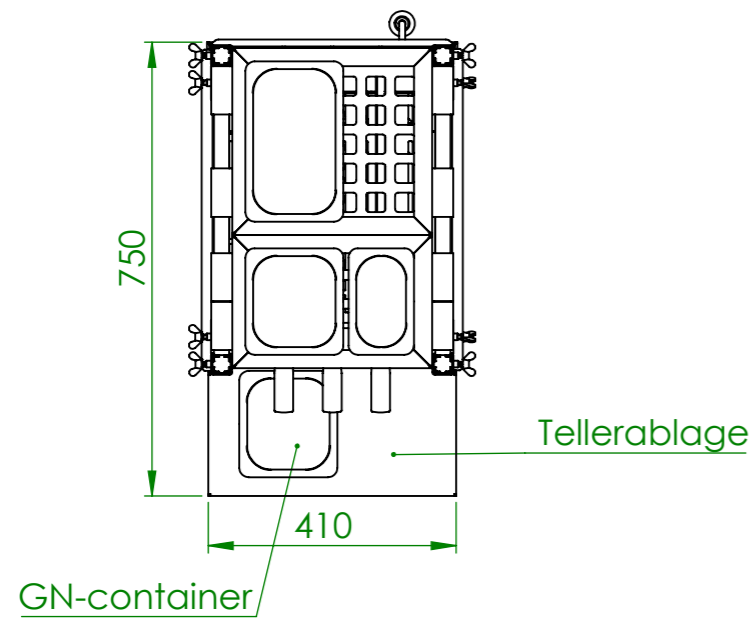
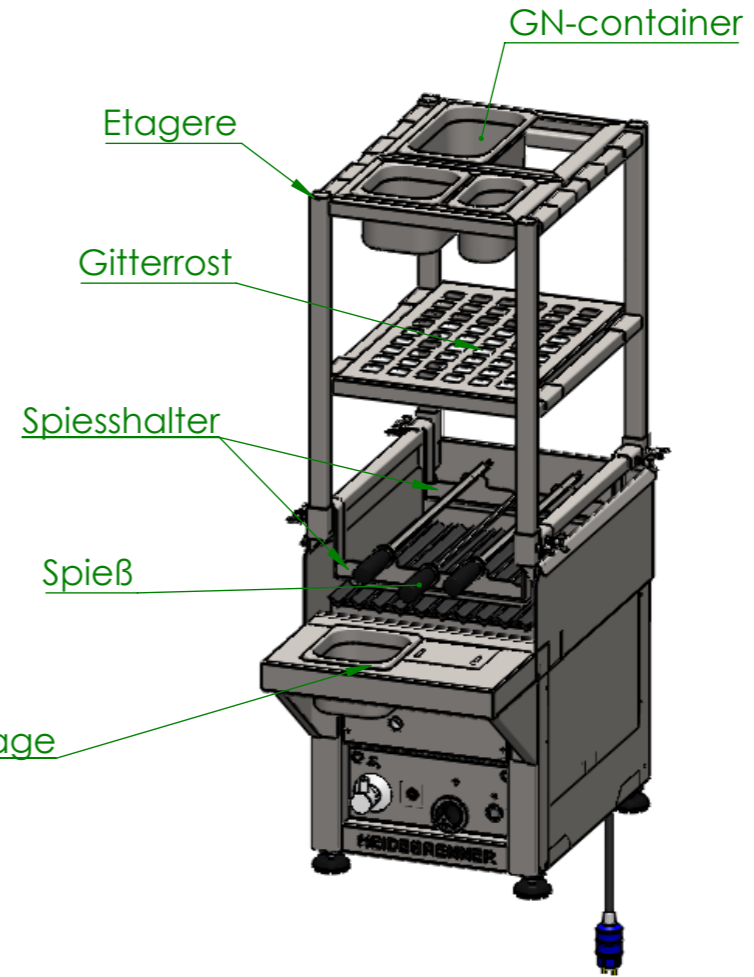
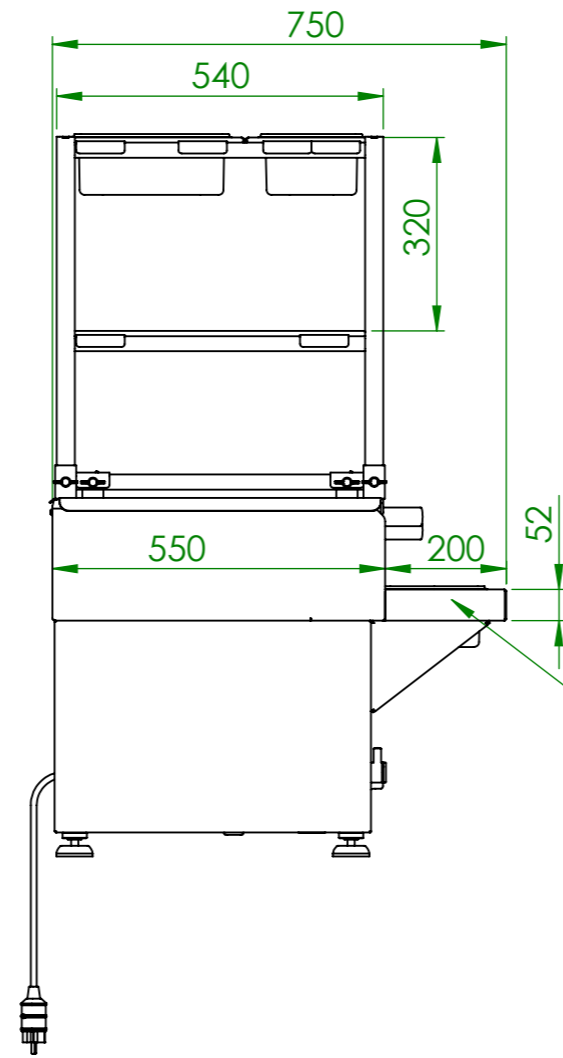
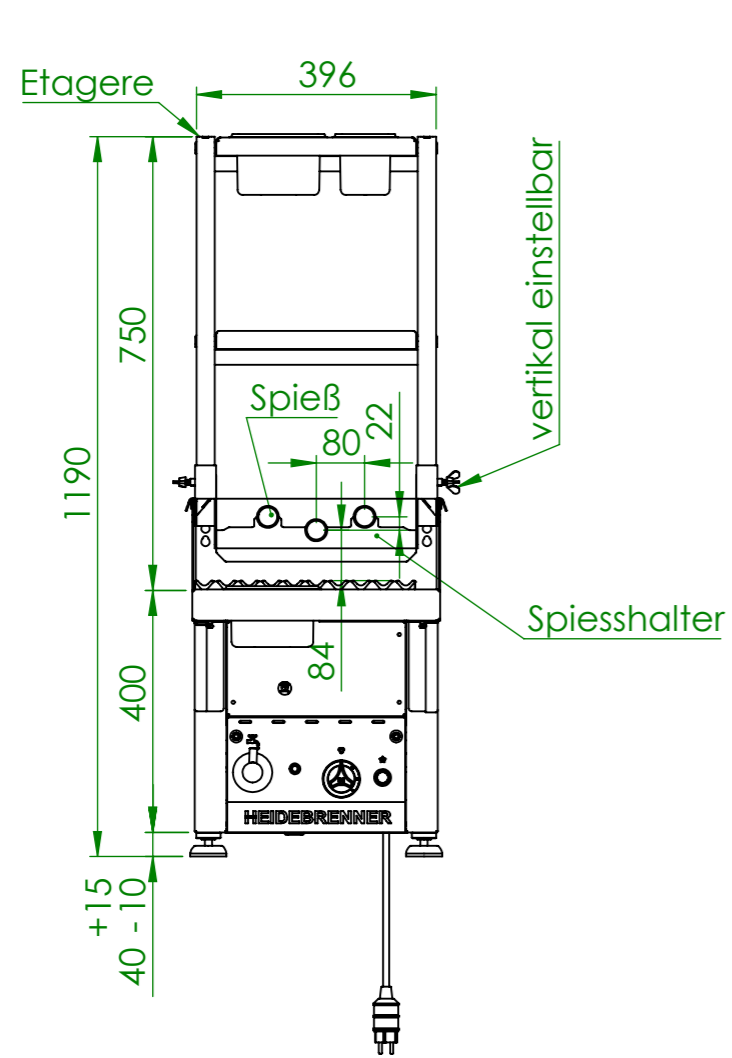

Verwendungsbereich 410x750x1190	Toleranz nach DIN ISO 2768-mK	Oberflächen DIN ISO 1302	Maßstab: 1:12.5	Gewicht: 83 kg
			Werkstoff 1.4301 AISI 304	
Name	Datum	<b>Gas Wassergrill PASADENA</b>		
Bearb. M.B.	15.07.2020			
<b>HEIDEBRENNER</b>		GNAA		A3