

Menge: 1xStück

POS.	BENENNUNG	BESCHREIBUNG	MENGE
1	ZCVP01 - 101	Gitterblech	1
2	ZCxx-113	U-Profil	4
3	50091	Blindnieten mit Flachrundkopf 5x8	12

Verwendungsbereich 1665x200x30	Toleranz nach DIN ISO 2768-mK	Oberflächen DIN ISO 1302	Maßstab: 1:8	Gewicht: 4.11 Kg
			Werkstoff Material <not specified>	
Name	Datum	Gitterauflage 1/3		
Bearb. M.B.	20/06/2019			
HEIDEBRENNER		ZCVP01		A3

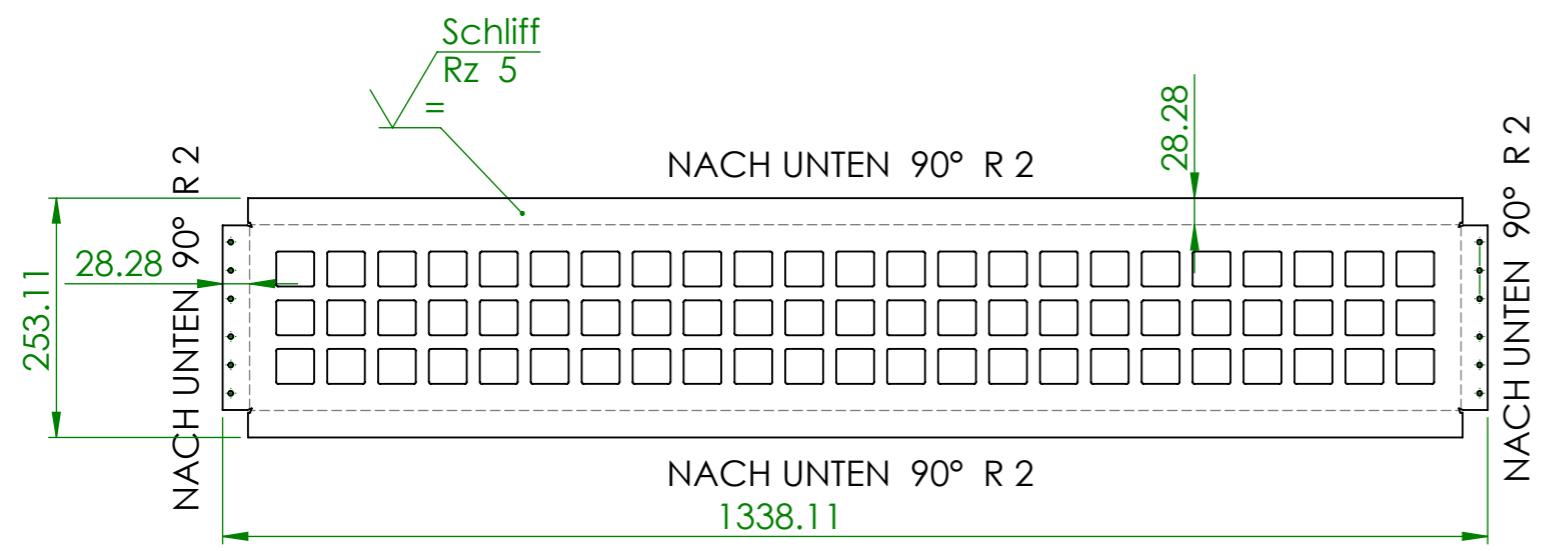
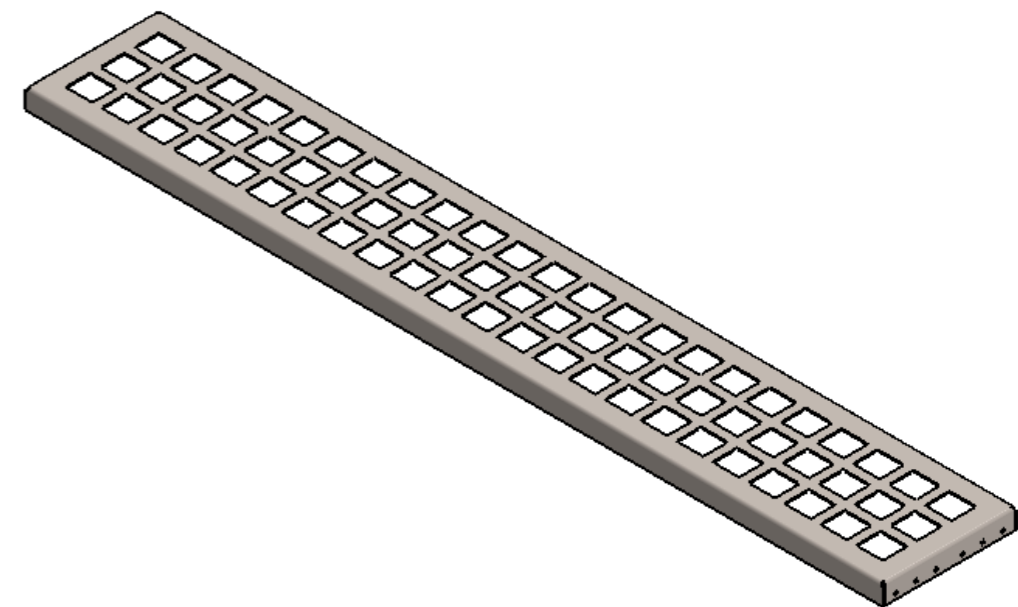
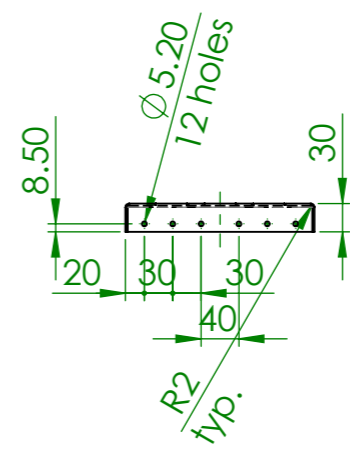
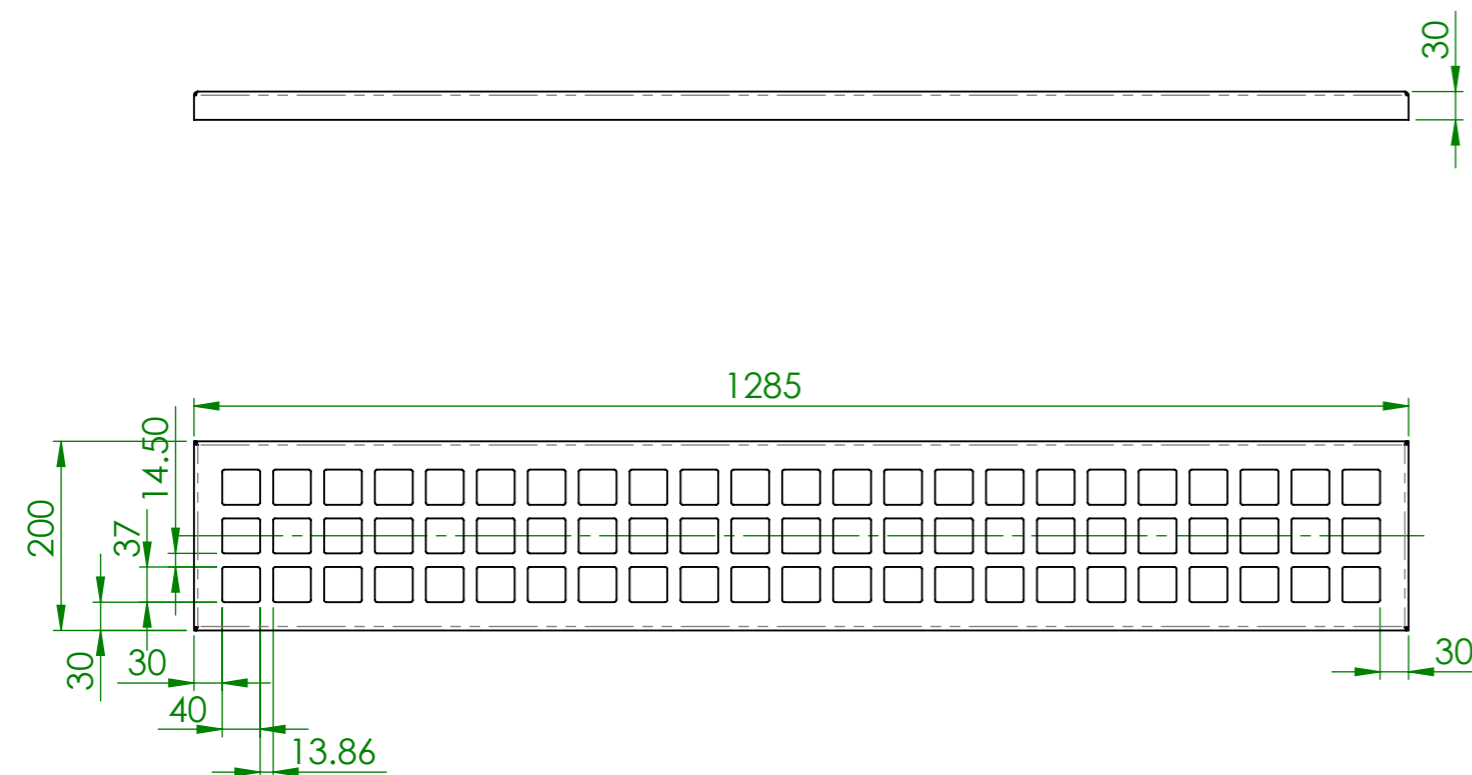

t=2mm; Menge: 4xStück

Verwendungsbereich 1285x200x30	Toleranz nach DIN ISO 2768-mK	Oberflächen DIN ISO 1302	Maßstab: 1:8	Gewicht: 3.70 Kg
		Werkstoff 1.4301 (X5CrNi18-10)		
Name	Datum	Etagere Grill		
Bearb. M.B.	20/06/2019			
HEIDEBRENNER		ZCVP01 Gitterauflage 1/3 ZCVP01 - 101 Gitter blech		A3

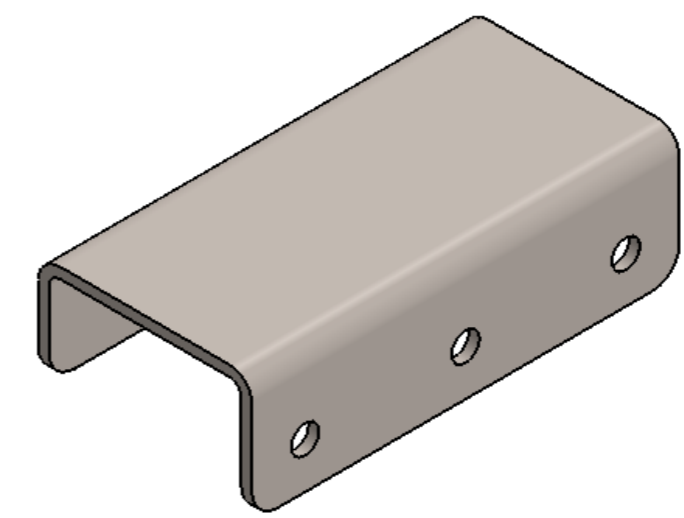
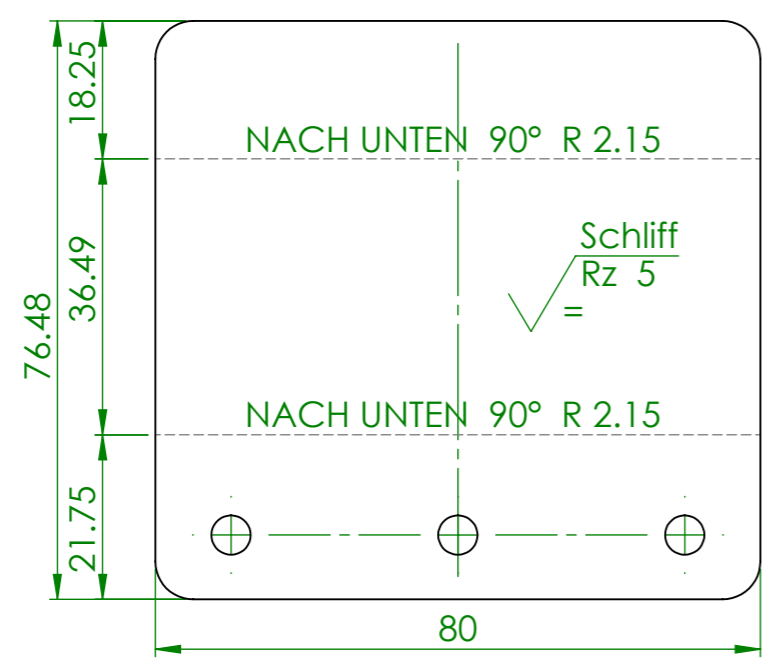
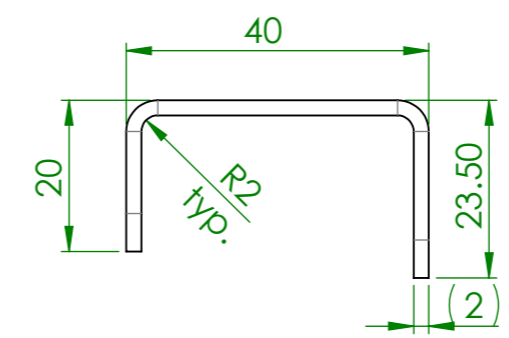
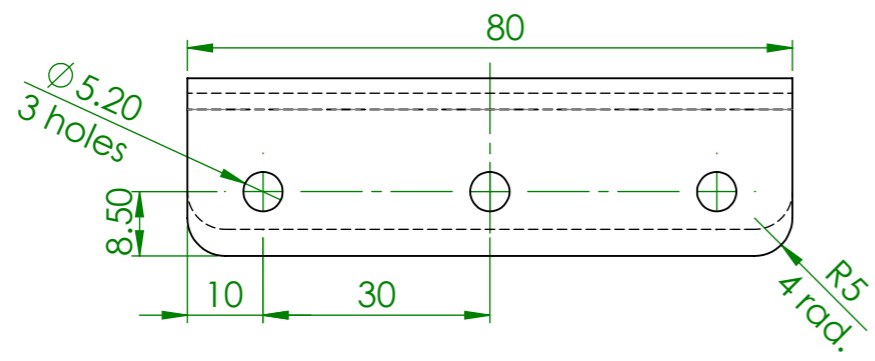

t=2mm; Menge: 4xStück

Verwendungsbereich 80x40x23,5	Toleranz nach DIN ISO 2768-mK	Oberflächen DIN ISO 1302	Maßstab: 1:1	Gewicht: 0.10 Kg
			Werkstoff 1.4301 (X5CrNi18-10)	
Name	Datum	Etagere Grill		
Bearb. M.B.	20/06/2019			
HEIDEBRENNER		ZCxx Gitter ZCxx- 113 U-profile		A3