

Verwendungsbereich 430x750x300	Toleranz nach DIN ISO 2768-mK	Oberflächen DIN ISO 1302	Maßstab: 1:10 Werkstoff: 1.4301 AISI 304	Gewicht: 55 Kg
Name	Datum	Elektro Lava/Wasser Grill LITLI		
Bearb. G.N.	17.03.2020			
<b>HEIDEBRENNER</b>		EFIAA - Einbaugerät		A3

Art. Nr	HZ	P[kW]	Wasser	Abwasser	Strom
EFIAA	1	4,5	G 1/2"	DN 50	CEE 32 A, 400V~ 3L+N+PE, 6h

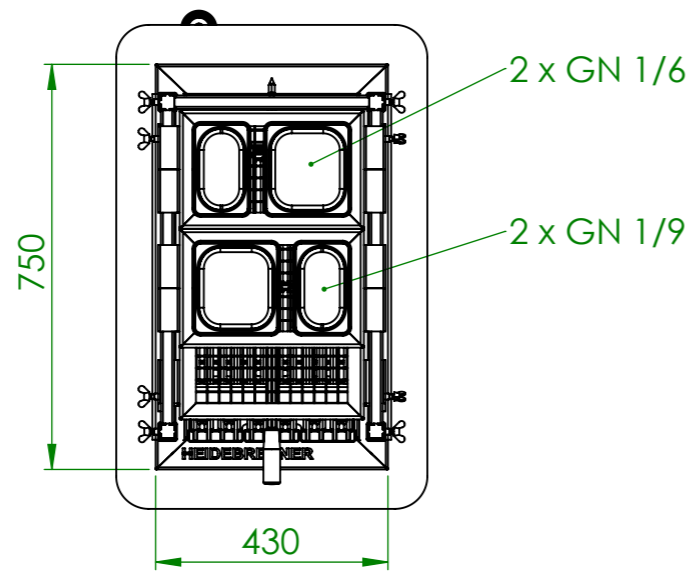

- ZQDM - 176 GN Halter
- ZQTM - 1/1 Gitterrost
- ZQSM - Etage
- ZMQM - Spiesshalter
- Spiess

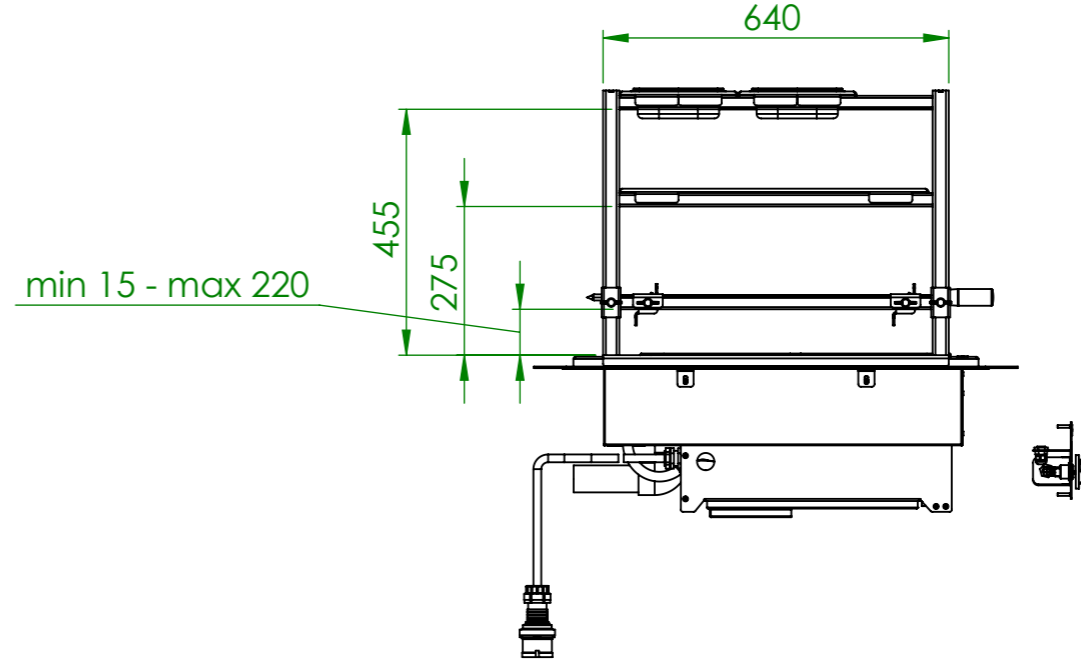
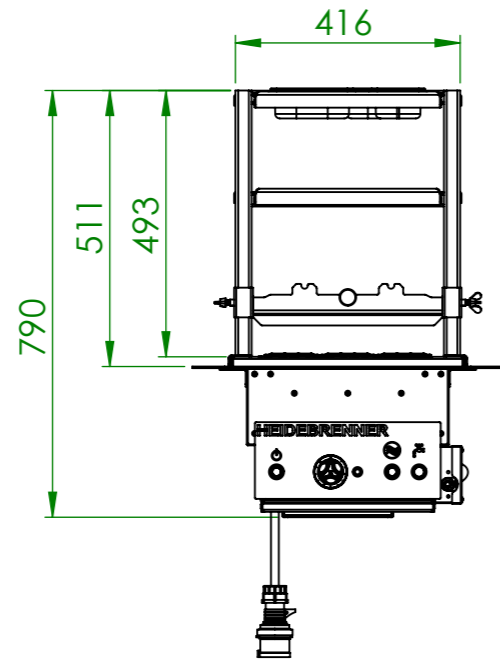
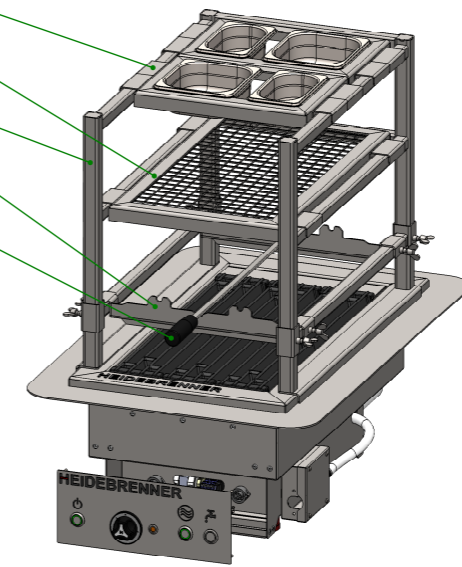

Verwendungsbereich 430x750x790	Toleranz nach DIN ISO 2768-mK	Oberflächen DIN ISO 1302	Maßstab: 1:14	Gewicht: 80 Kg
			Werkstoff 1.4301 AISI 304	
Name	Datum	Elektro Lava/Wasser Grill LITLI		
Bearb. G.N.	02.04.2020			
<b>HEIDEBRENNER</b>		EFIAA + ETAGERE		A3

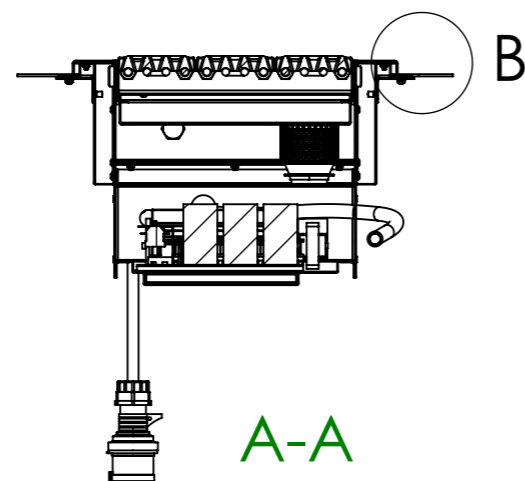

A-A

B

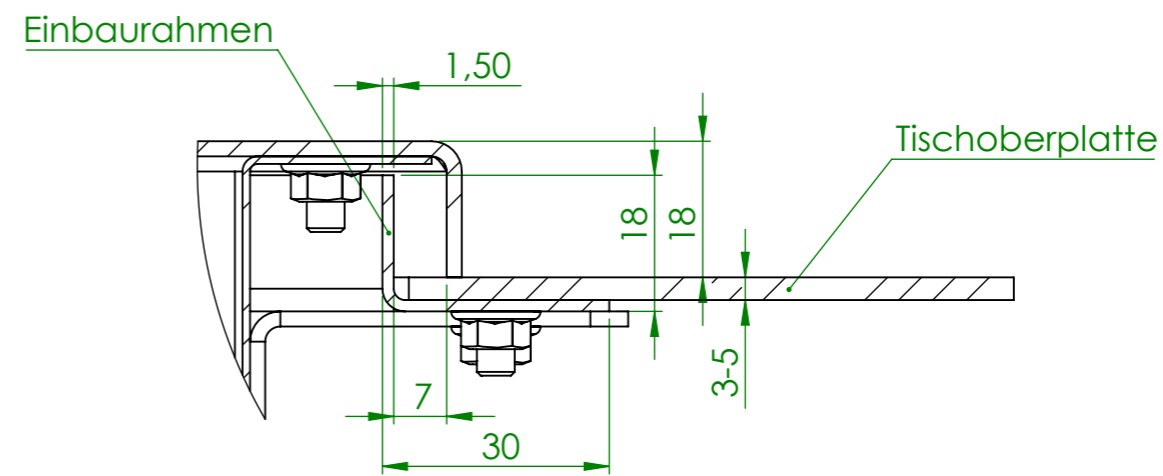

B (1 : 1)

## AUSSCHNITTMASS

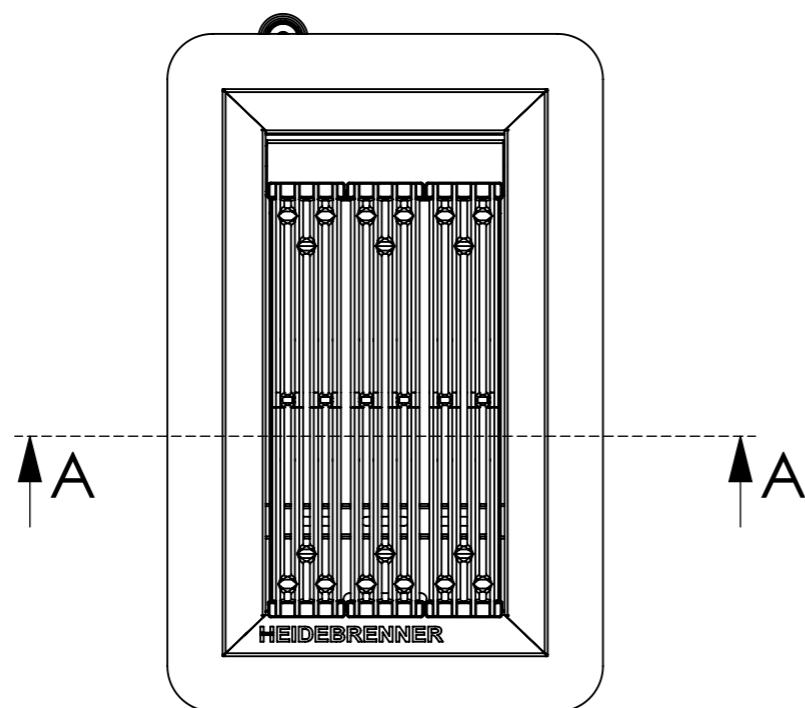

Gerät

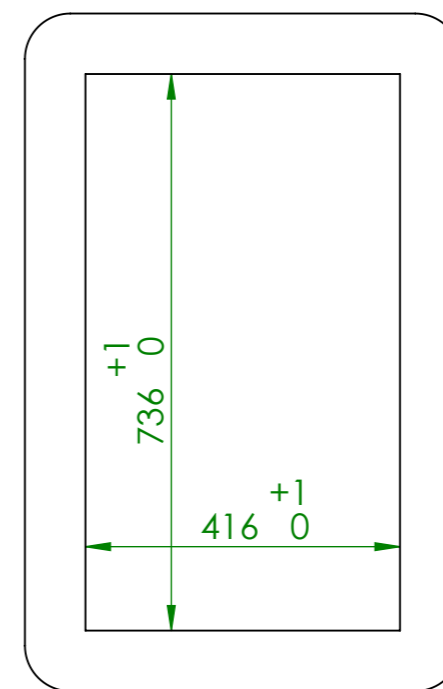

Verwendungsbereich 430x750x300	Toleranz nach DIN ISO 2768-mK	Oberflächen DIN ISO 1302	Maßstab: 1:10	Gewicht: 35 Kg
			Werkstoff 1.4301 AISI 304	
Name	Datum	Elektro Lava/Wasser Grill LITLI		
Bearb. G.N.	17.03.2020			
<b>HEIDEBRENNER</b>		EFIAA - Einbaugerät		A3

# BLENDE

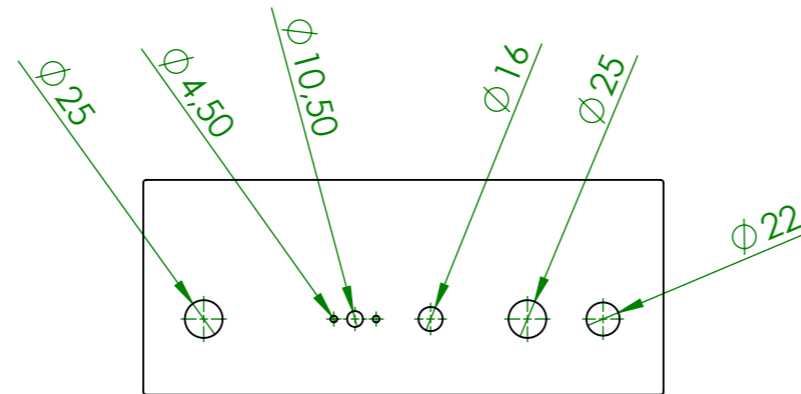
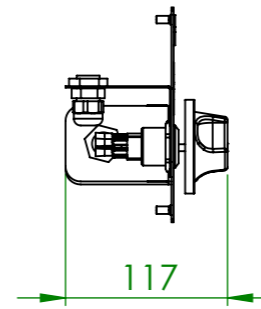
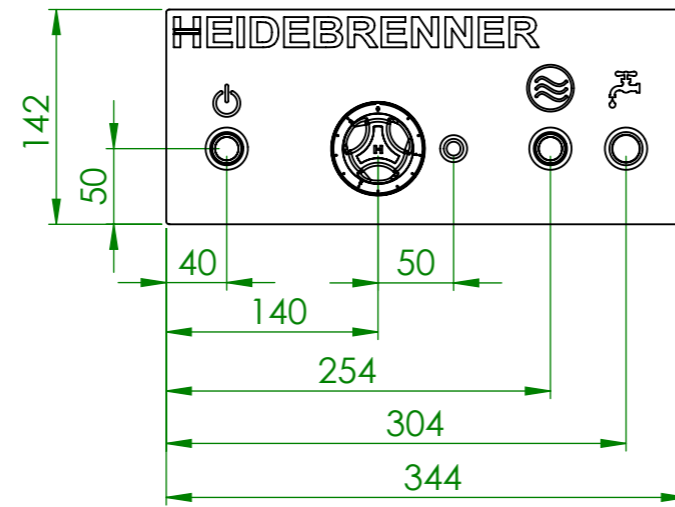

Verwendungsbereich 430x750x300	Toleranz nach DIN ISO 2768-mK	Oberflächen DIN ISO 1302	Maßstab: 1:10	Gewicht: 35 Kg
			Werkstoff	1.4301 AISI 304
Name	Datum	Elektro Lava/Wasser Grill LITLI		
Bearb. G.N.	18.03.2020			
<b>HEIDEBRENNER</b>		EFIAA - Einbaugerät		A3

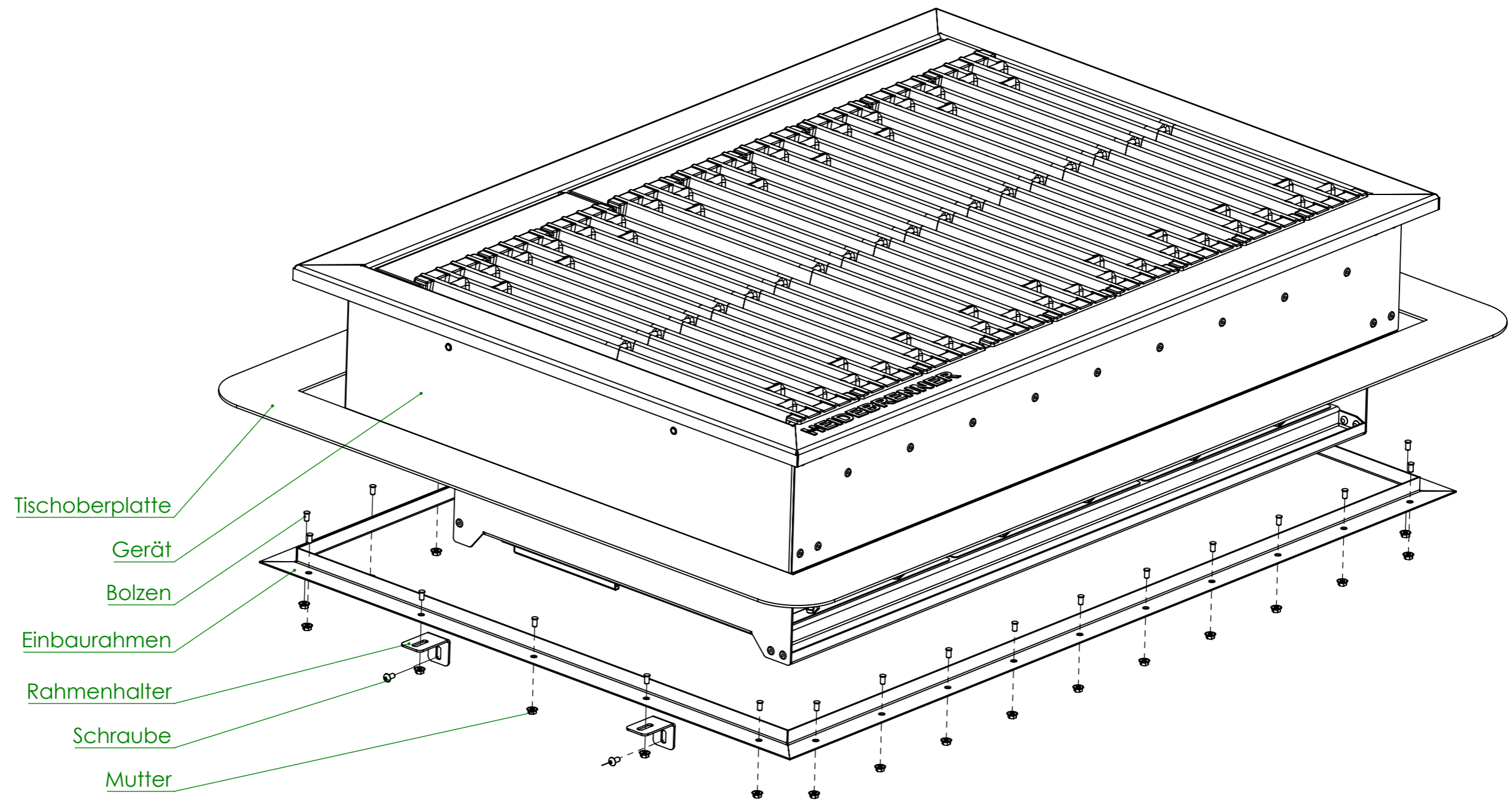

- Tischoberplatte
- Gerät
- Bolzen
- Einbaurahmen
- Rahmenhalter
- Schraube
- Mutter

Verwendungsbereich 430x750x300	Toleranz nach DIN ISO 2768-mK	Oberflächen DIN ISO 1302	Maßstab: 1:10	Gewicht: 35 Kg
			Werkstoff 1.4301 AISI 304	
Name	Datum	Elektro Lava/Wasser Grill LITLI		
Bearb. G.N.	17.03.2020			
<b>HEIDEBRENNER</b>		EFIAA - Einbaugerät		A3