

Verwendungsbereich 740x650x1000	Toleranz nach DIN ISO 2768-mK	Oberflächen DIN ISO 1302	Maßstab: 1:16	Gewicht: 128.38 kg
			Werkstoff 1.4301	
Name	Datum		Gas Wassergrill DENTON	
Bearb. M.B.	15.07.2020			
HEIDEBRENNER			GNEB	A3

Artikel Nr.	P [kW]	Pges [kW]	Volumenstrom V [m3/h]	Gasanschluß [Zoll]	Länge Verbrauchsleitung [m] delta p=0.6mBar
GNEB	2x9,3	18,6	1,97	3/4"	6

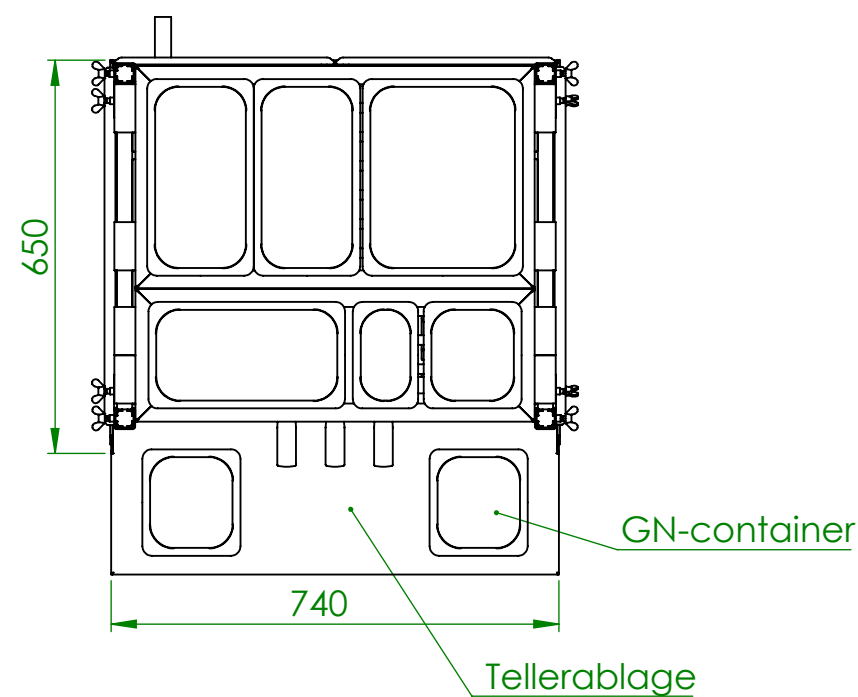
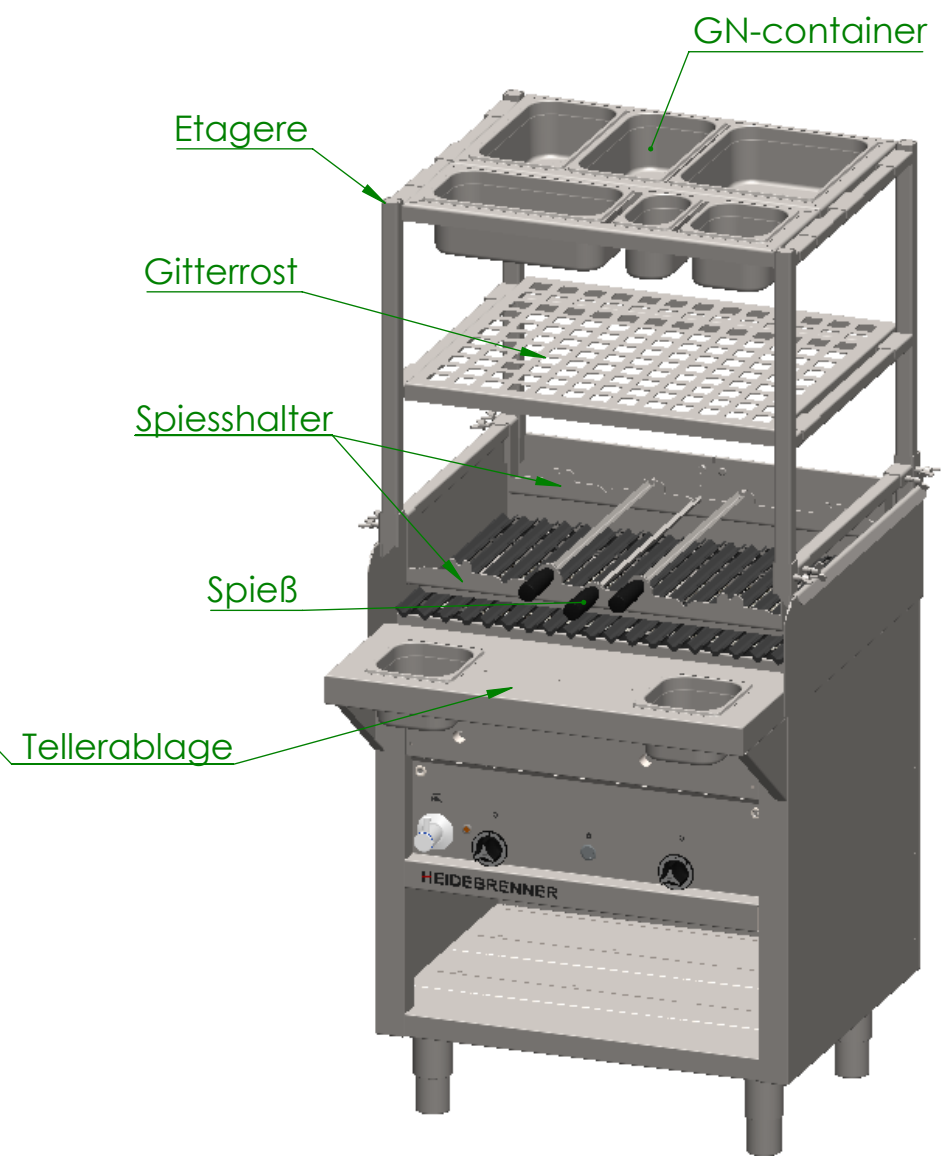
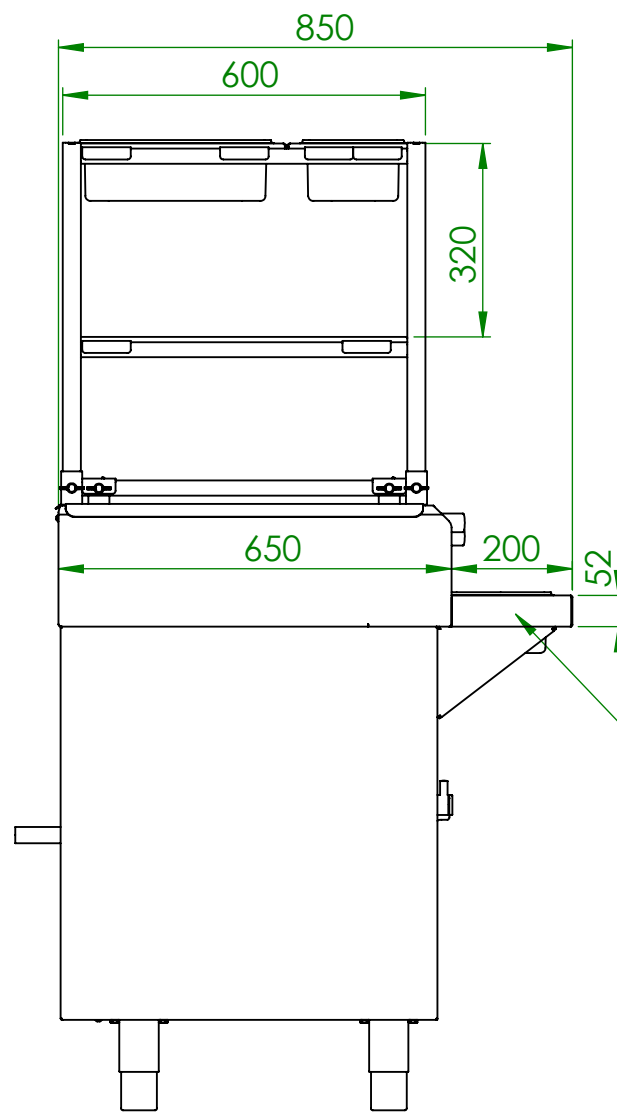
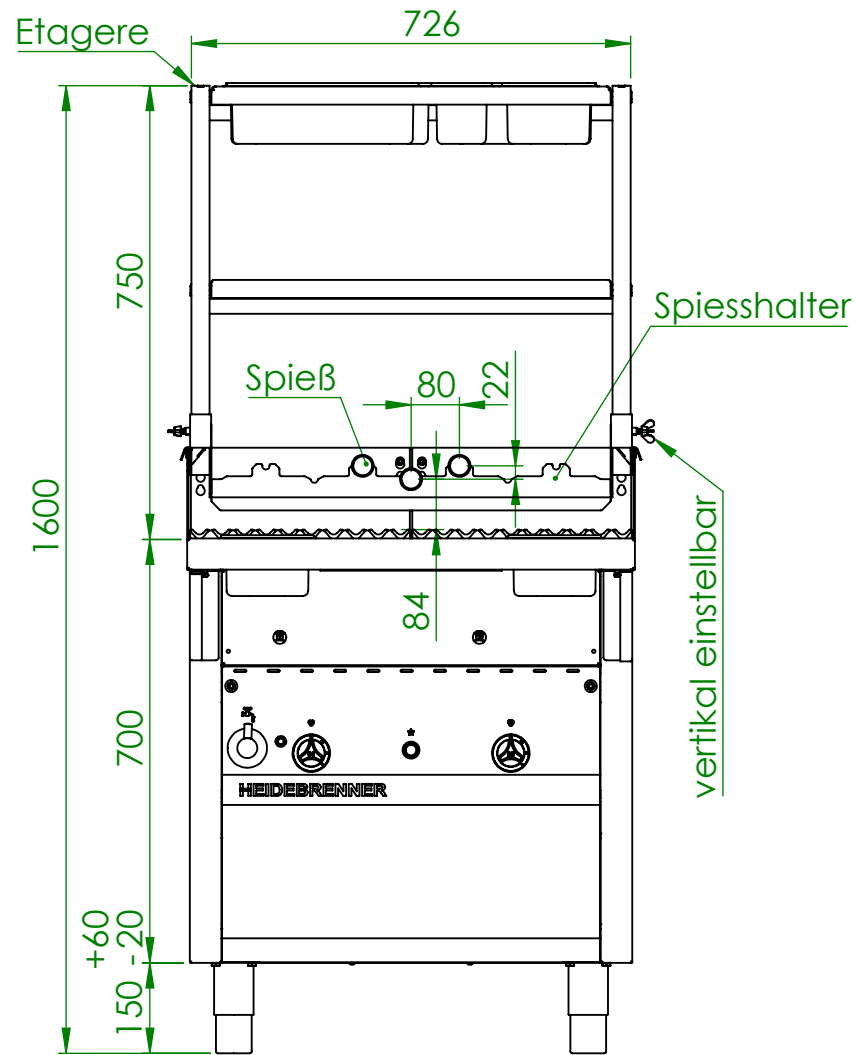

Verwendungsbereich 740x850x1600	Toleranz nach DIN ISO 2768-mK	Oberflächen DIN ISO 1302	Maßstab: 1:12.5	Gewicht: 163 kg
			Werkstoff 1.4301 AISI 304	
Name	Datum	Gas Wassergrill DENTON		
Bearb. M.B.	15.07.2020			
HEIDEBRENNER		GNEB		A3