

Verwendungsbereich 1730x750x590	Toleranz nach DIN ISO 2768-mK	Oberflächen DIN ISO 1302	Maßstab: 1:16	Gewicht: 299.61 kg
			Werkstoff 1.4301	

Name	Datum	Gas Wassergrill SAN ANTONIO
Bearb. M.B.	15.07.2020	

Artikel Nr.	P [kW]	Pges [kW]	Volumenstrom V [m3/h]	Gasanschluß [Zoll]	Länge Verbrauchsleitung [m] delta p=0.6mBar
GNGE	5x12,8	64,0	6.77	1"	6

HEIDEBRENNER

GNGE

A3

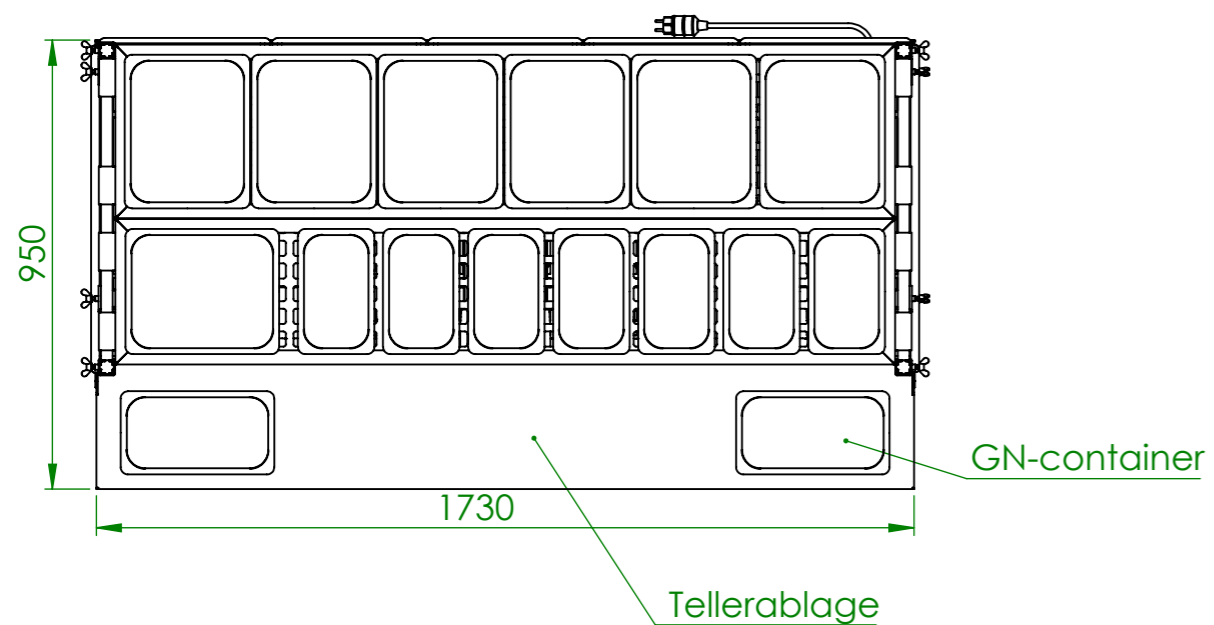
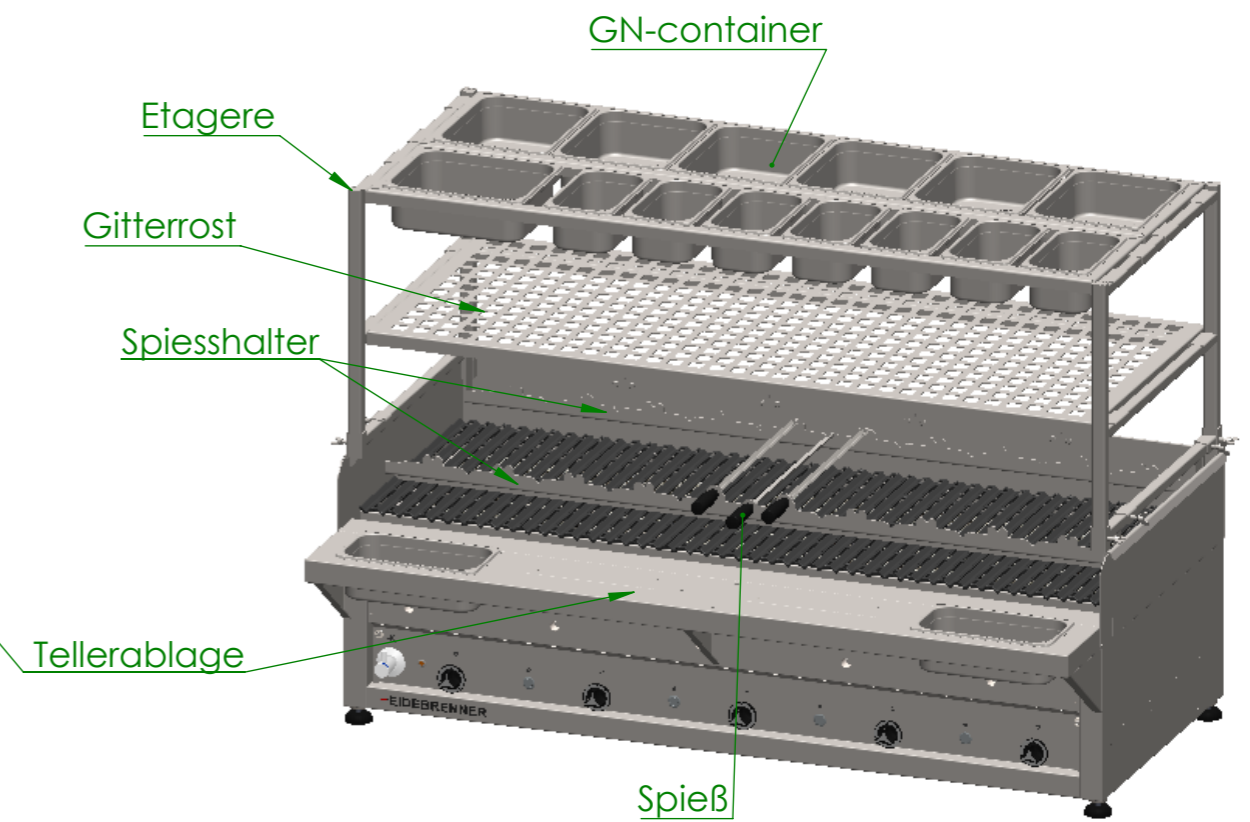
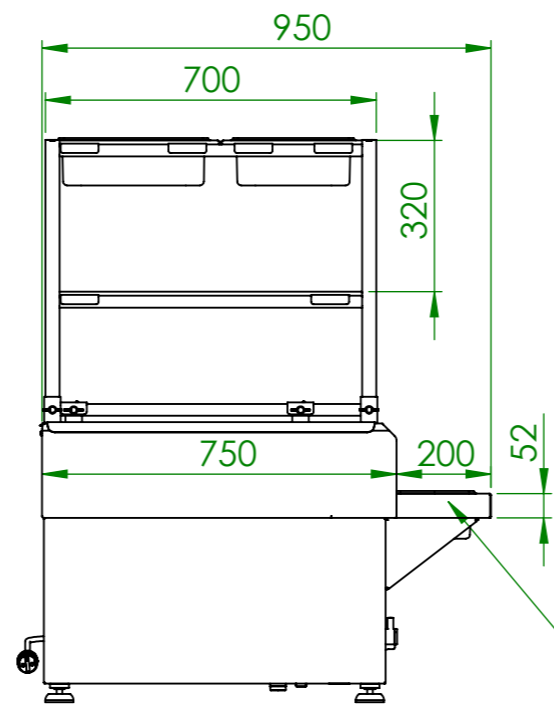
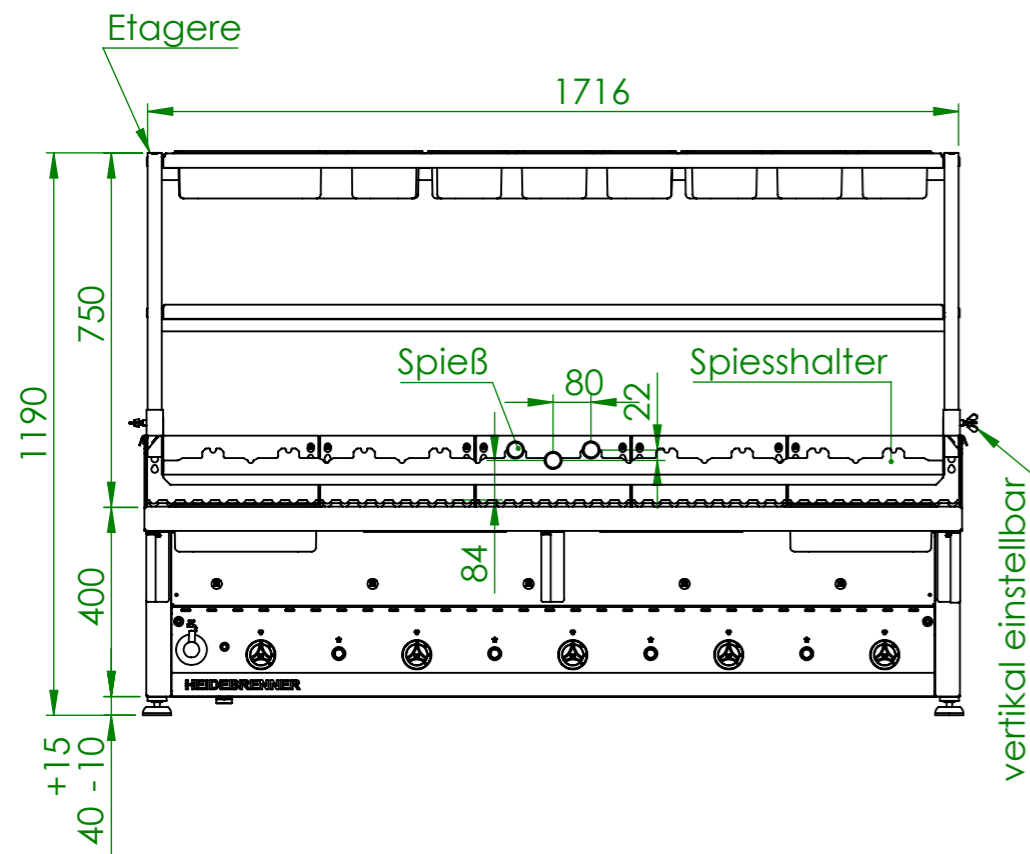

Verwendungsbereich 1730x950x1190	Toleranz nach DIN ISO 2768-mK	Oberflächen DIN ISO 1302	Maßstab: 1:16 Werkstoff 1.4301 AISI 304	Gewicht: 362 kg
Name	Datum	Gas Wassergrill SAN ANTONIO		
Bearb. M.B.	15.07.2020			
HEIDEBRENNER		GNGE		A3