

Verwendungsbereich 430x650x350	Toleranz nach DIN ISO 2768-mK	Oberflächen DIN ISO 1302	Maßstab: 1:10	Gewicht: 45 kg
			Werkstoff 1.4301 AISI 304	
Name	Datum	Elektro Lava/Wasser Grill LITLI		
Bearb. G.N.	17.03.2020			
HEIDEBRENNER		EFDAA - Tischgerät		A3

Art. Nr	HZ	P[kW]	Wasser	Abwasser	Strom
EFDAA	1	4,5	G 1/2"	DN 50	CEE 32 A, 400V~ 3L+N+PE, 6h

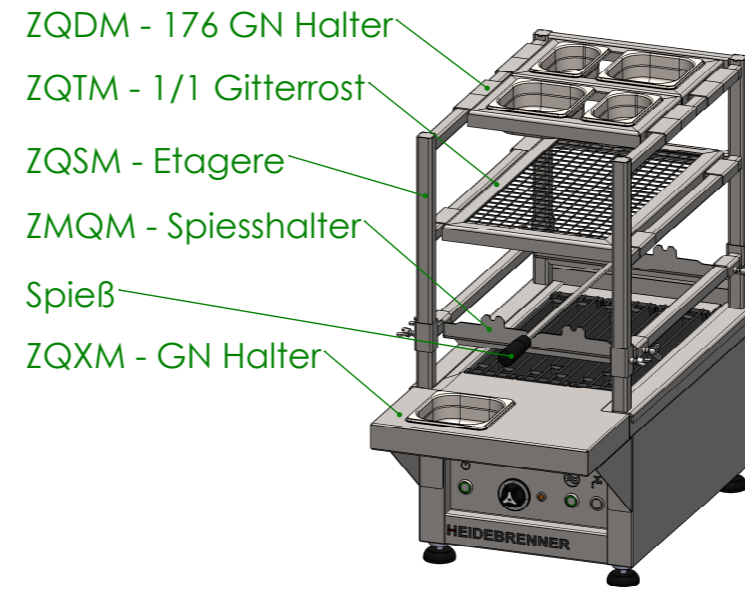
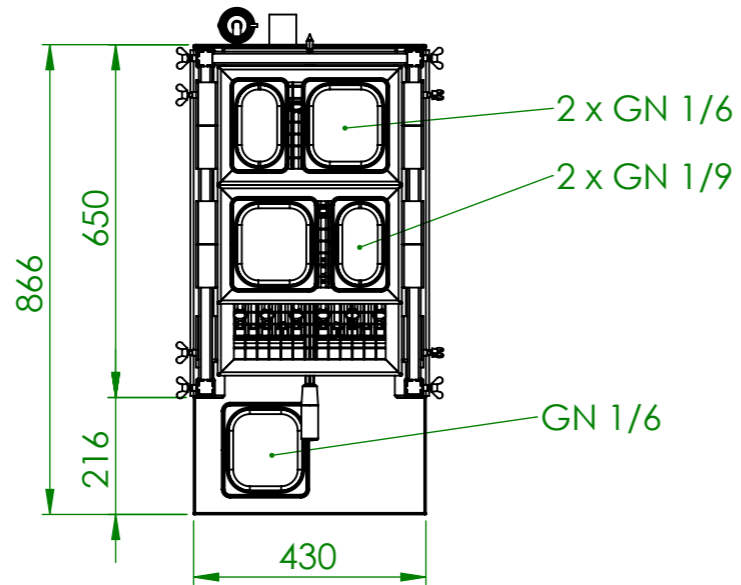
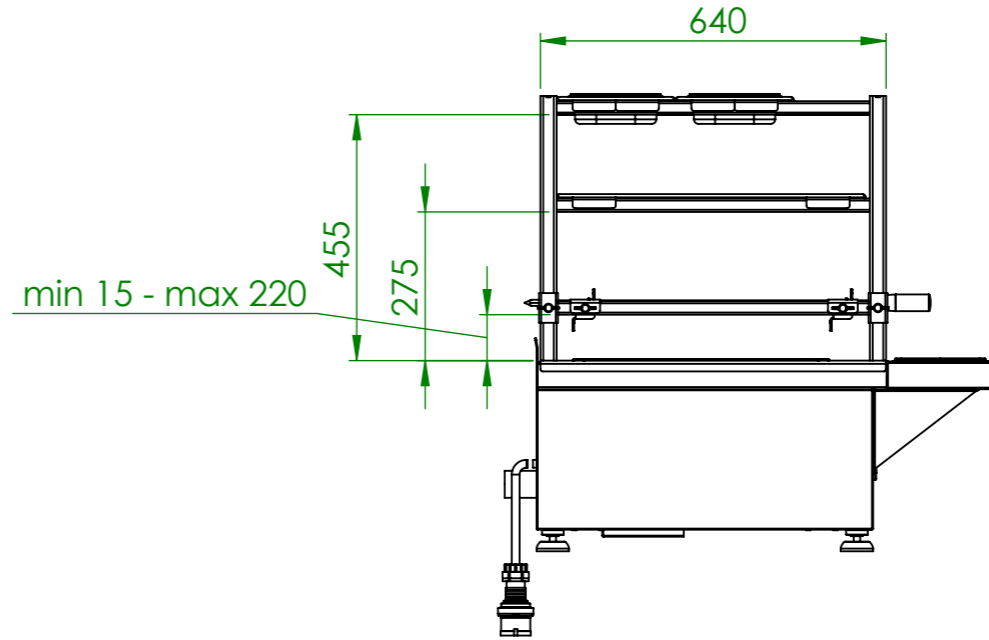
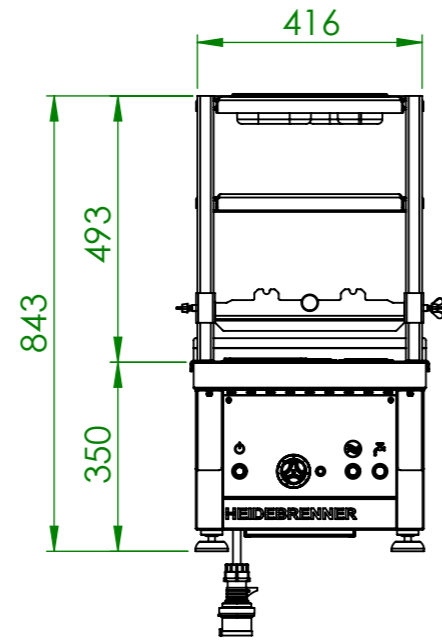

Verwendungsbereich 430x866x843	Toleranz nach DIN ISO 2768-mK	Oberflächen DIN ISO 1302	Maßstab: 1:14 Werkstoff 1.4301 AISI 304	Gewicht: 70 kg
Name	Datum	Elektro Lava/Wasser Grill LITLI		
Bearb. G.N.	01.04.2020			
HEIDEBRENNER		EFDA + ETAGERE		A3