

Artikel Nr.	P [kW]	Pges [kW]	Volumenstrom V [m3/h]	Gasanschluß [Zoll]	Länge Verbrauchsleitung [m] delta p=0.6mBar
GMAB	2x7,5	15,0	1.59	3/4"	6

Verwendungsbereich 740x550x590	Toleranz nach DIN ISO 2768-mK	Oberflächen DIN ISO 1302	Maßstab: 1:8 Werkstoff 1.4301	Gewicht: 96.67 kg
Name	Datum	Gas Lavastein Grill KOS		
Bearb. M.B.	15.07.2020			
HEIDEBRENNER		GMAB		A3

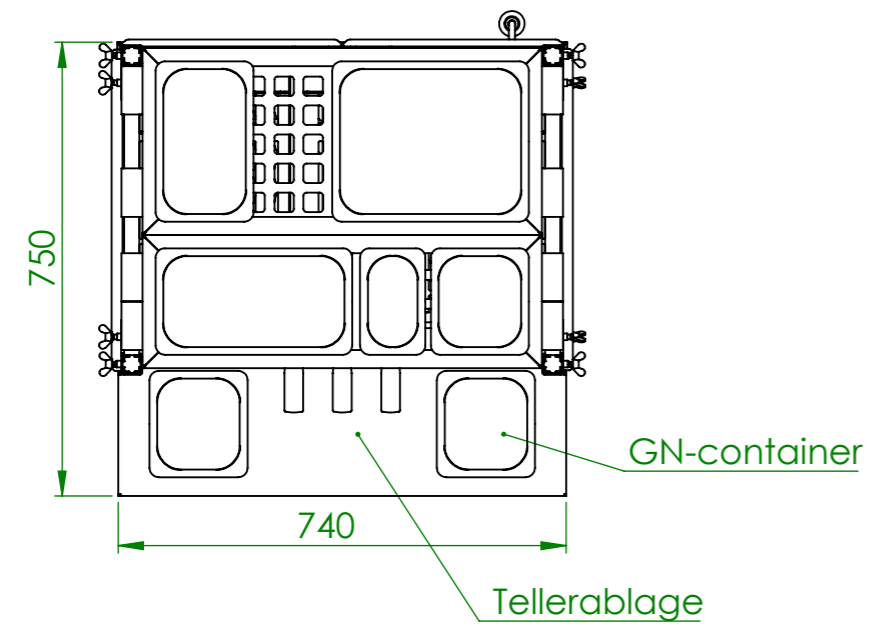
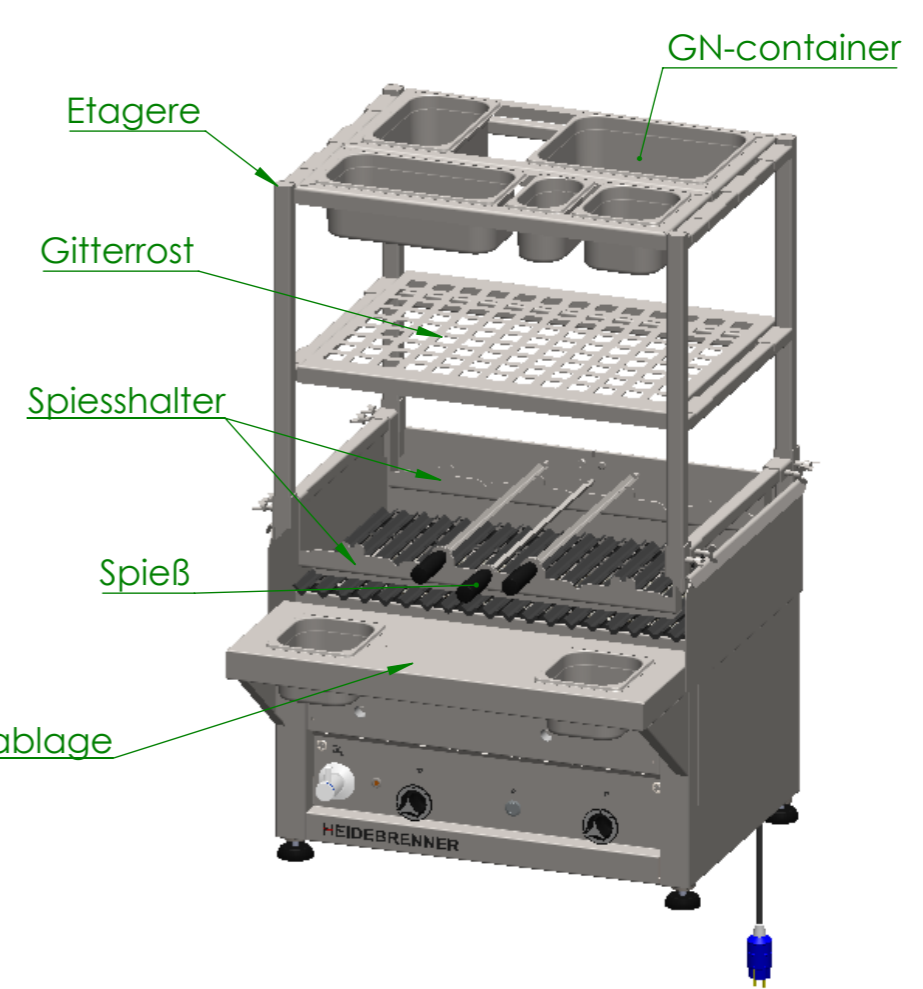
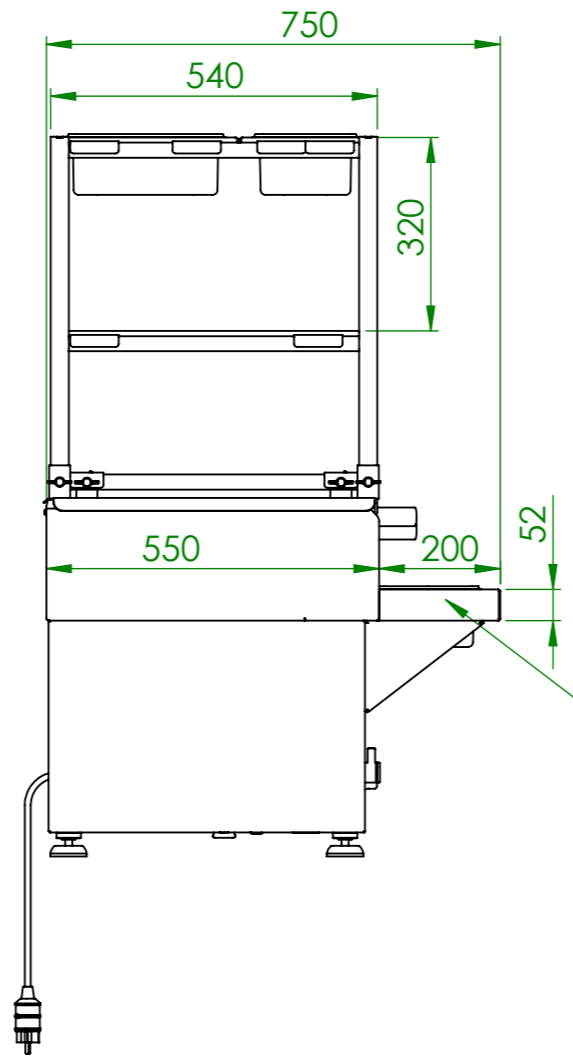
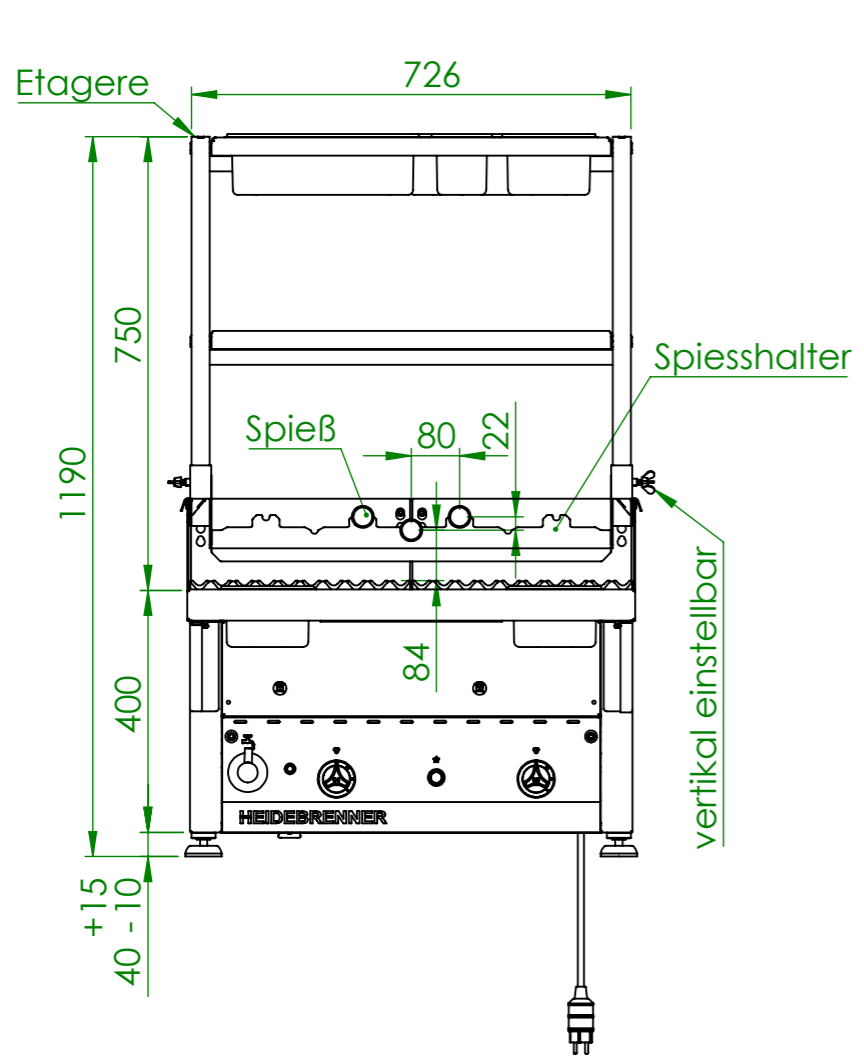

Verwendungsbereich 740x850x1600	Toleranz nach DIN ISO 2768-mK	Oberflächen DIN ISO 1302	Maßstab: 1:12.5	Gewicht: 130 kg
			Werkstoff 1.4301 AISI 304	
Name	Datum	Gas Lavastein-Grill KOS		
Bearb. M.B.	15.07.2020			
HEIDEBRENNER		GMAB		A3