

Verwendungsbereich 1070x650x1000	Toleranz nach DIN ISO 2768-mK	Oberflächen DIN ISO 1302	Maßstab: 1:16	Gewicht: 194.47 kg
			Werkstoff 1.4301	
Name	Datum	<b>Gas Lavastein-Grill ÄTNA</b>		
Bearb. M.B.	28.03.2022			
<b>HEIDEBRENNER</b>		<b>GMEC01</b>		A3

Artikel Nr.	P [kW]	Pges [kW]	Volumenstrom V [m3/h]	Gasanschluß [Zoll]	Länge Verbrauchsleitung [m] delta p=0.6mBar
GMEC01	3x9.3	27.9	2.95	3/4"	6

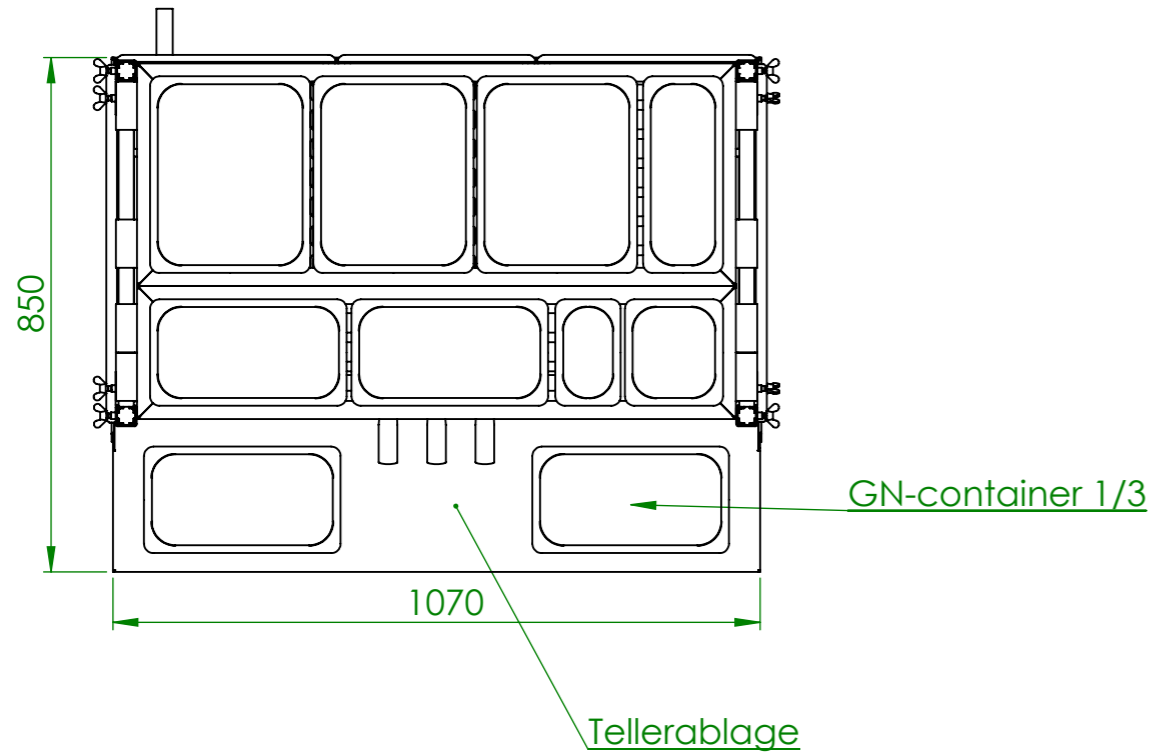
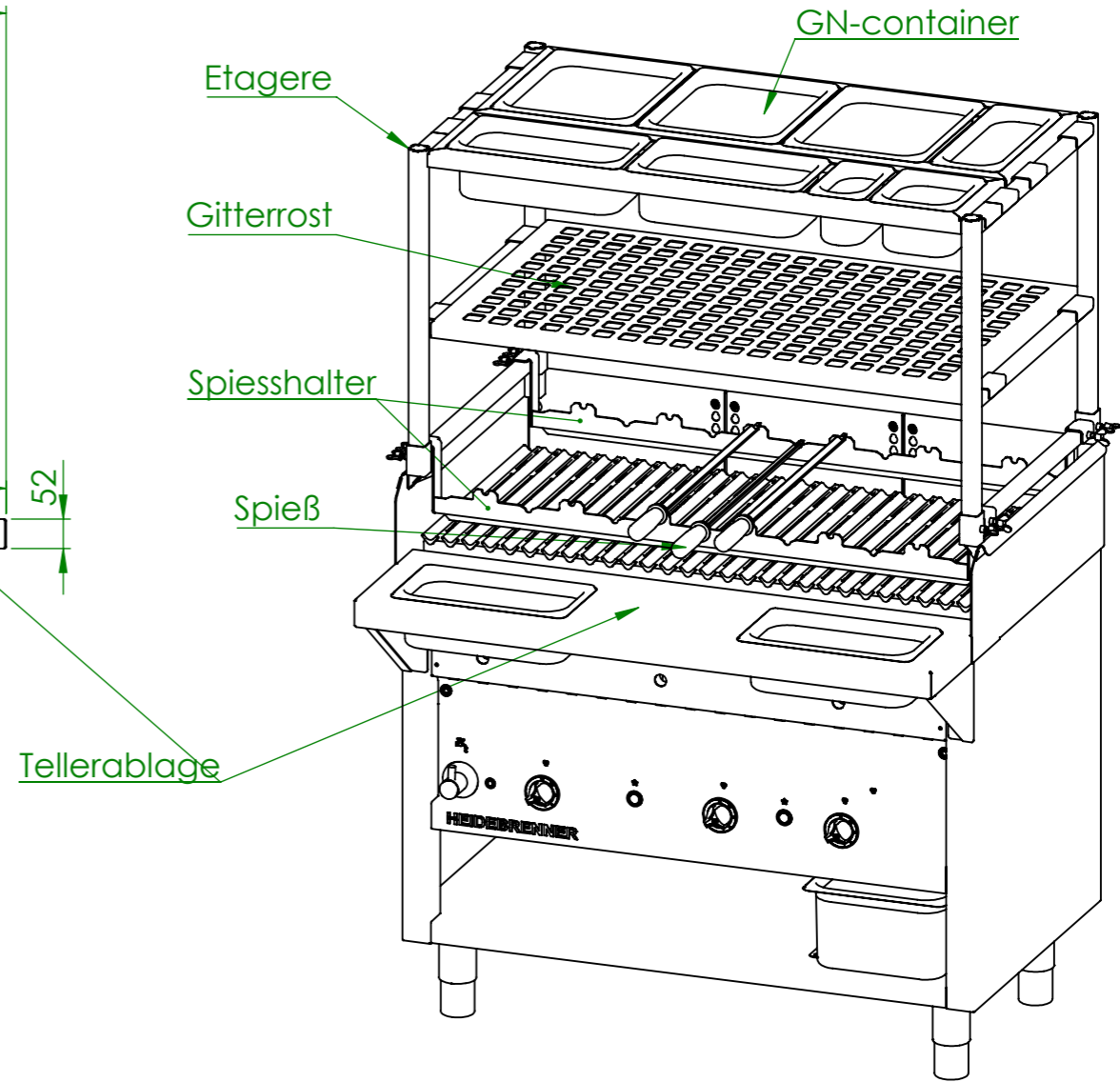
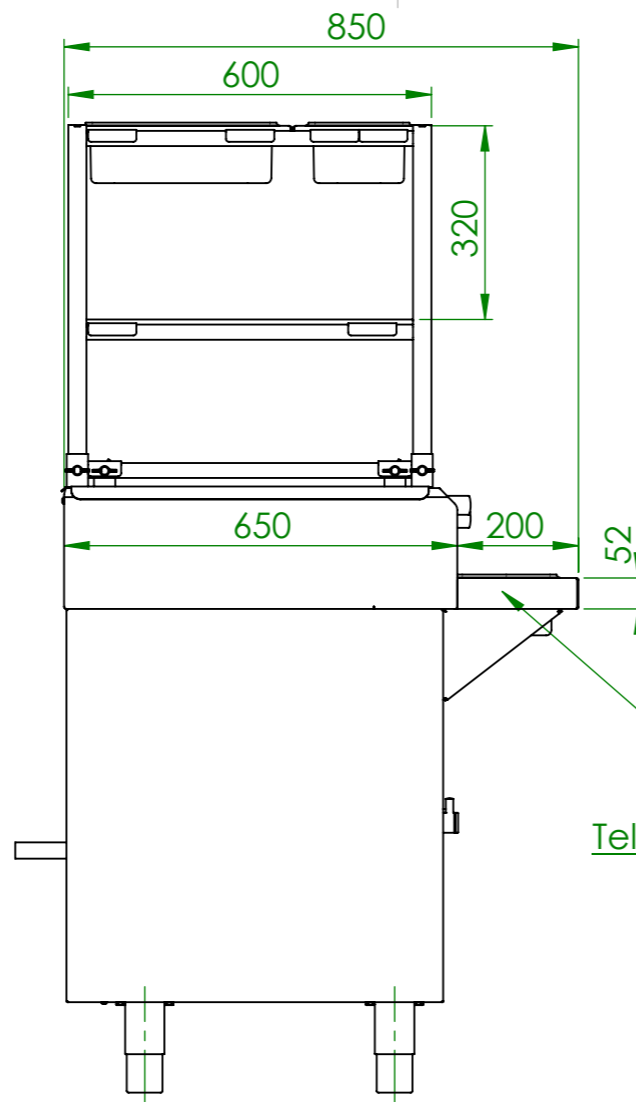
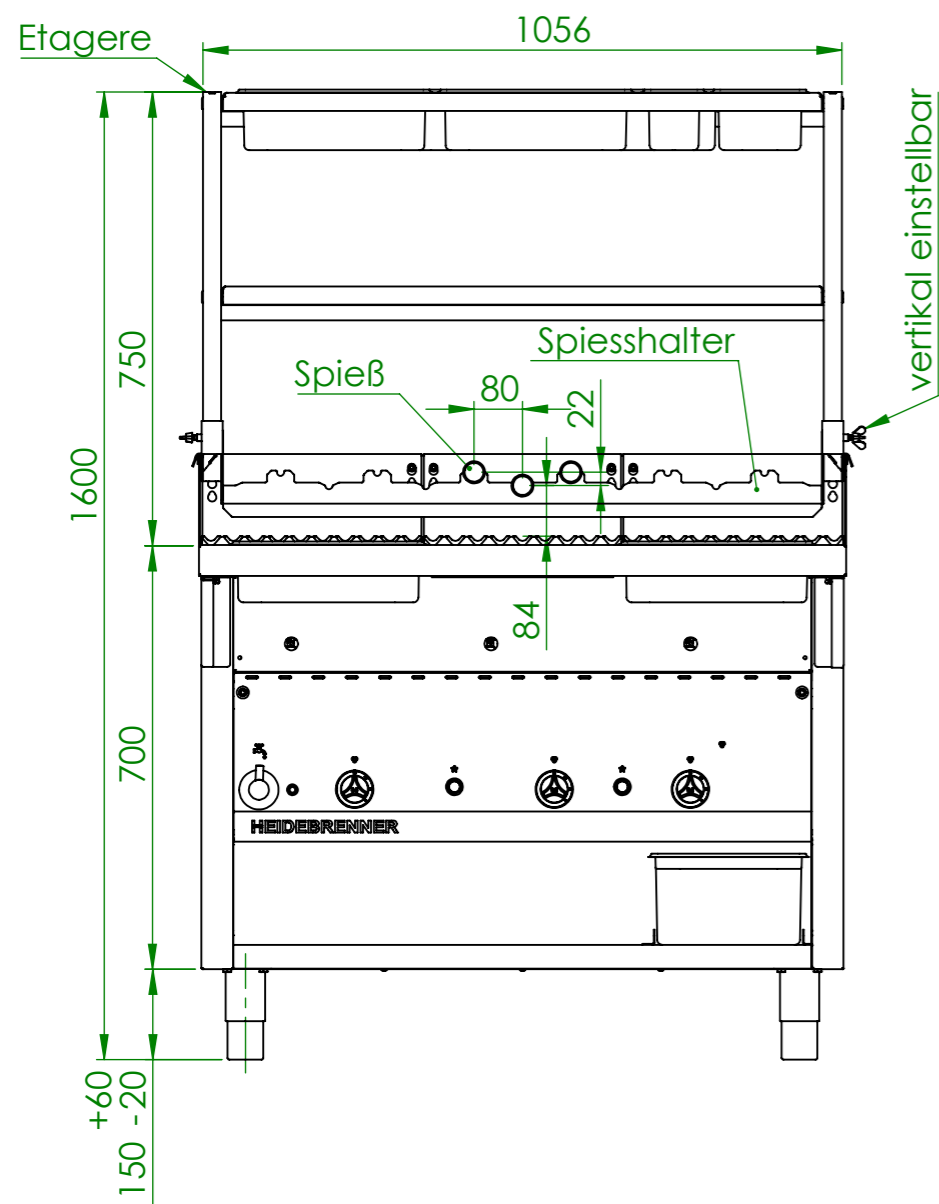

Verwendungsbereich 1070x850x1600	Toleranz nach DIN ISO 2768-mK	Oberflächen DIN ISO 1302	Maßstab: 1:12.5	Gewicht: 242.73kg
			Werkstoff 1.4301 AISI 304	
Name	Datum		<b>Gas Lavastein-Grill ÄTNA</b>	
Bearb. M.B.	28.03.2022			
<b>HEIDEBRENNER</b>			GMEC01+Etagere+GN keeper	
			A3	