

Schnittansicht
Guß V-Rost Art.Nr. ZQXA

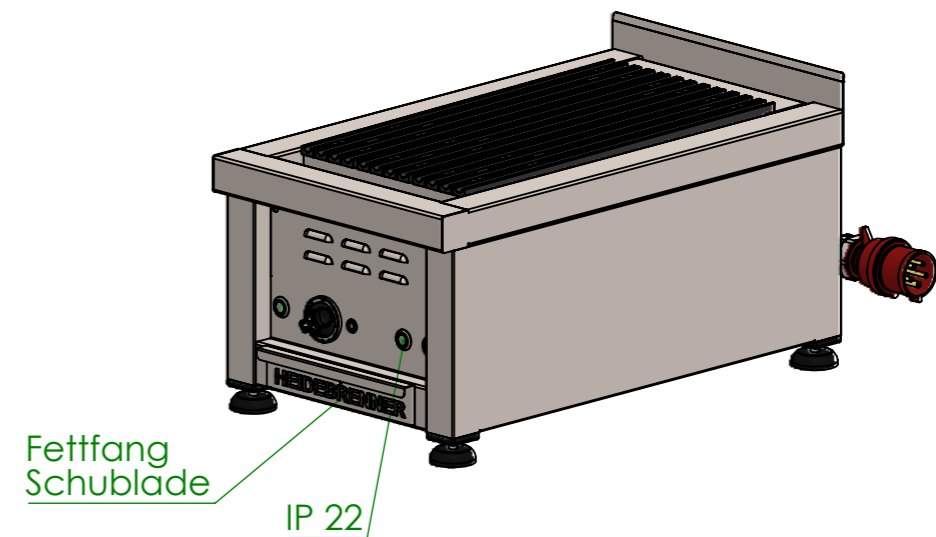
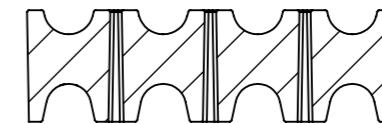

| | | | | |
|-----------------------------------|----------------------------------|-----------------------------|-----------------------------------|-------------------|
| Verwendungsbereich 430x750x350 | Toleranz nach DIN ISO 2768-mK | Oberflächen DIN ISO 1302 | Maßstab: 1:10 Werkstoff 1.4301 | Gewicht: 66.30 Kg |
| Name | Datum | Elektro Lava/Wasser Grill | | |
| Bearb. E.B. | 17.10.2016 | | | |
| HEIDEBRENNER | | EFGAA | | A3 |

| | | | | |
|--------------|--------------|----|-----------|-----------------------------|
| Wasserzulauf | Wasserablauf | HZ | Pges [kW] | Anschlußstecker |
| G 1/2" | DN 50 | 1 | 4,5 | CEE 16 A, 400V~ 3L+N+PE, 6h |