

1 2 3 4 5 6 7 8

A

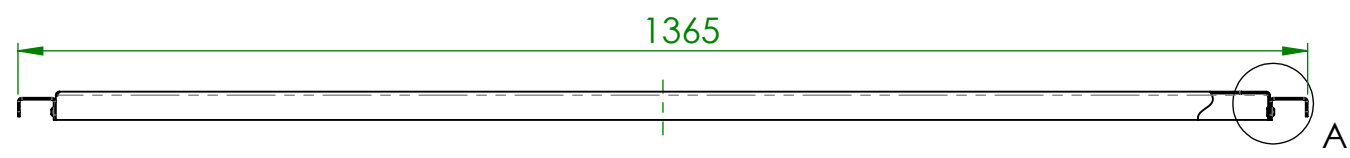

B

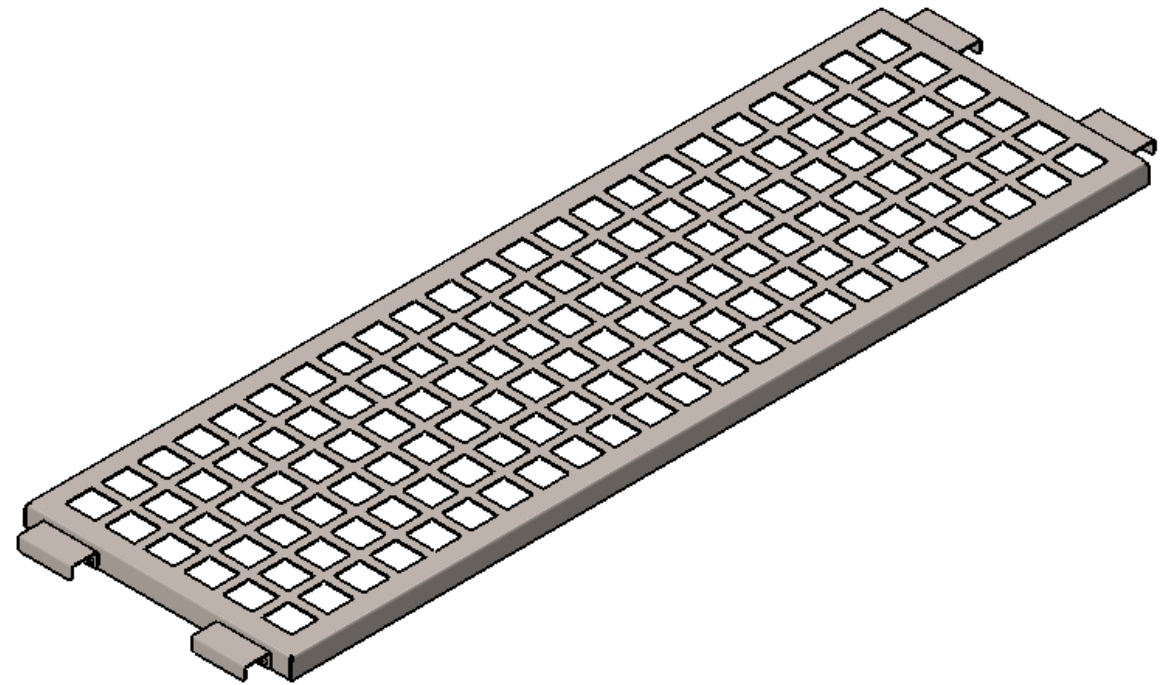
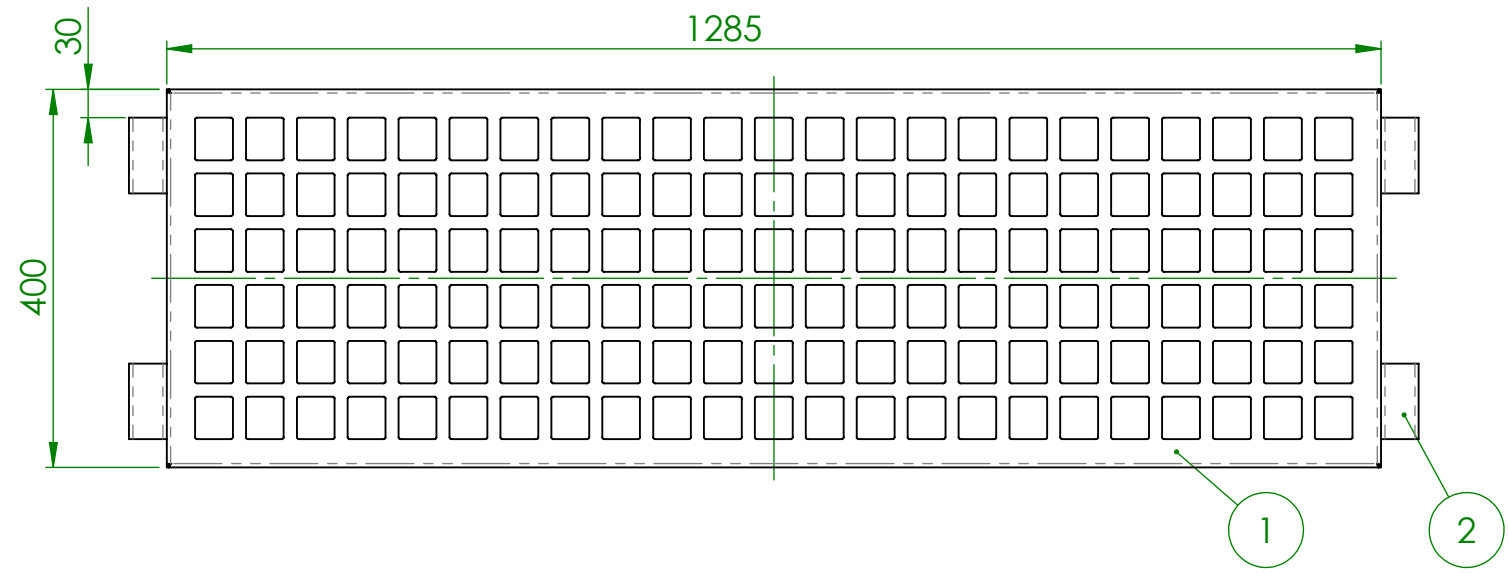

C

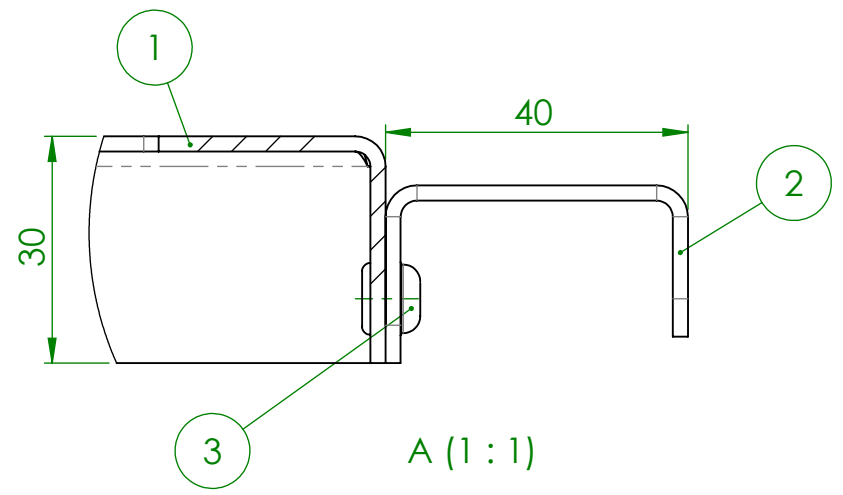

D

Menge: 1xStück

E

POS.	BENENNUNG	BESCHREIBUNG	MENGE
1	ZCUP01 2/3 -101	Gitterblech	1
2	ZCxx-113	U-Profil	4
3	50091	Blindnieten mit Flachrundkopf 5x8	12

Verwendungsbereich 1365x400x30	Toleranz nach DIN ISO 2768-mK	Oberflächen DIN ISO 1302	Maßstab: 1:8	Gewicht: 6.03 Kg
			Werkstoff Material <not specified>	
Name	Datum	Induktion Bratplatte		
Bearb. M.B.	07/06/2019			
HEIDEBRENNER		ZCUP01-Gitter unten ZCUP01__2_3		A3

F

1 2 3 4

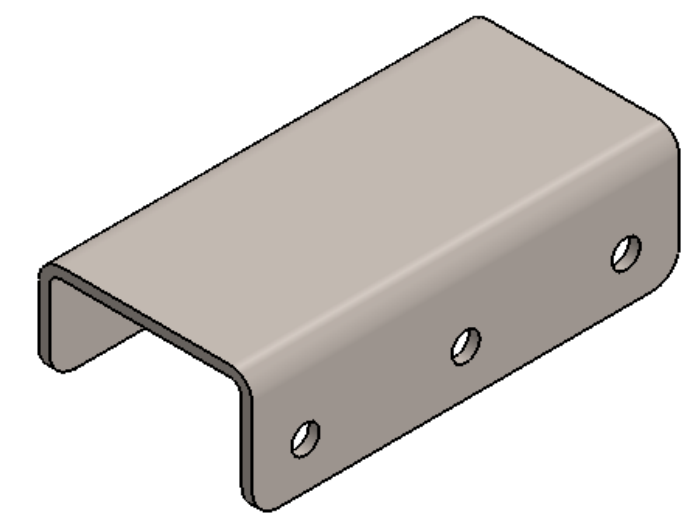
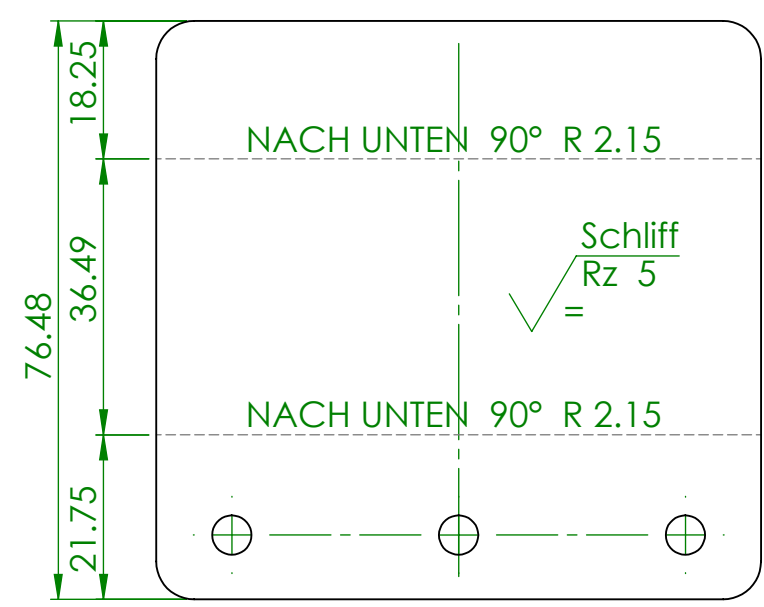
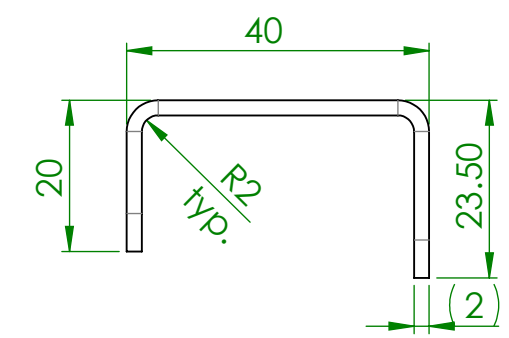
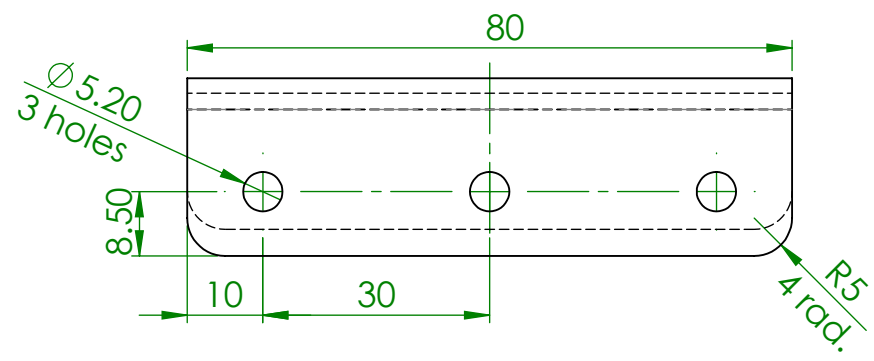

t=2mm; Menge: 4xStück

Verwendungsbereich 80x40x23,5	Toleranz nach DIN ISO 2768-mK	Oberflächen DIN ISO 1302	Maßstab: 1:1	Gewicht: 0.10 Kg
			Werkstoff 1.4301 (X5CrNi18-10)	
Name	Datum		Etagere Grill	
Bearb. M.B.	07/06/2019			
HEIDEBRENNER			ZCxx Gitter ZCxx- 113 U-profile	
				A3