

Nach oben 90° R 3.3
 Nach unten 90° R 3.3

Schliff
 Rz 5
 =

t=3mm; Menge: 1xStück

Verwendungsbereich 1282x77x42	Toleranz nach DIN ISO 2768-mK	Oberflächen DIN ISO 1302	Maßstab: 1:4 Werkstoff: 1.4301 AISI 304	Gewicht: 3.04 kg
Name	Datum	Etagere Grill		
Bearb. M.B.	07/06/2019			
HEIDEBRENNER		ZMOP Spießhalter ZMOP-109-1 Spießhalter		A3

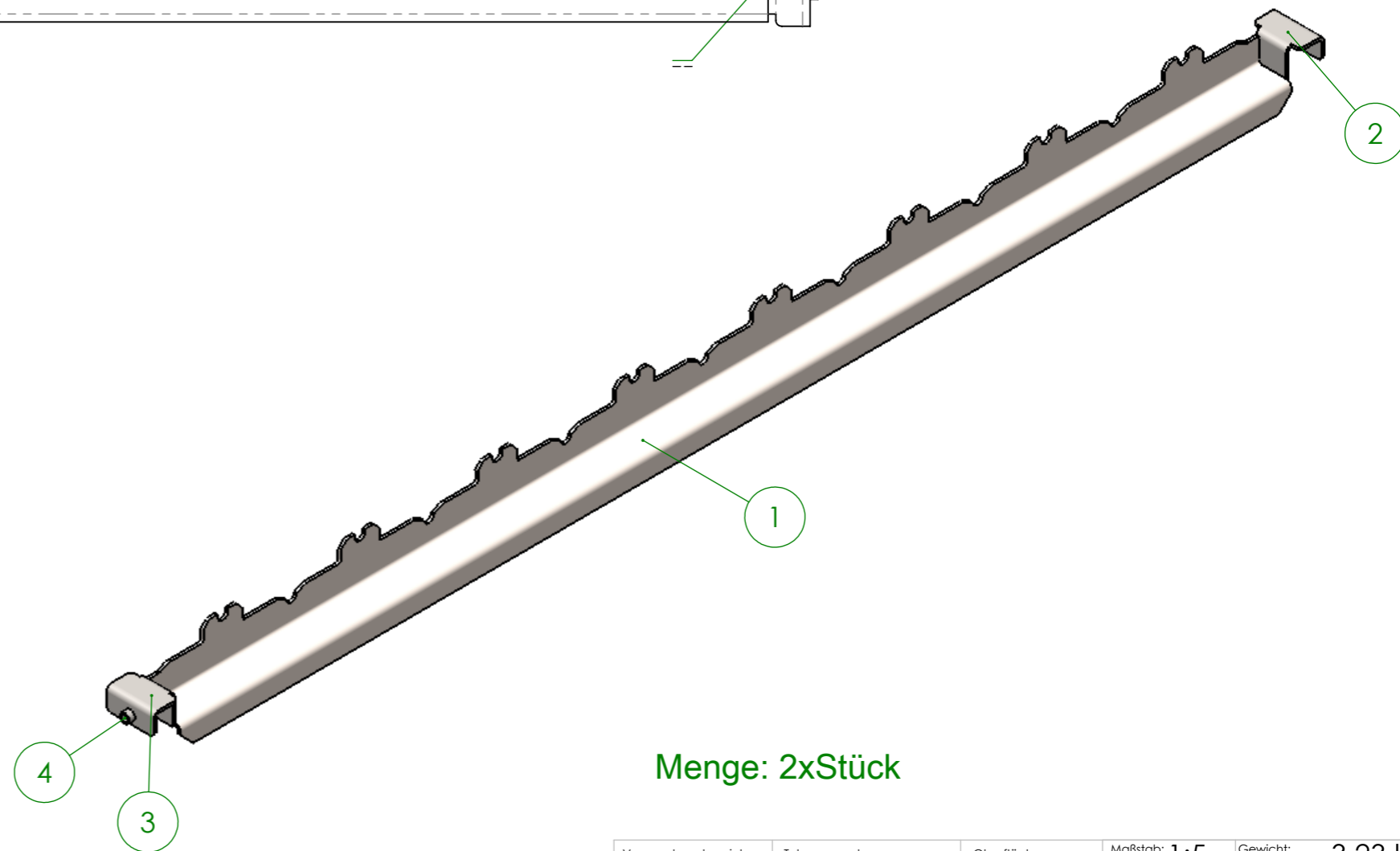
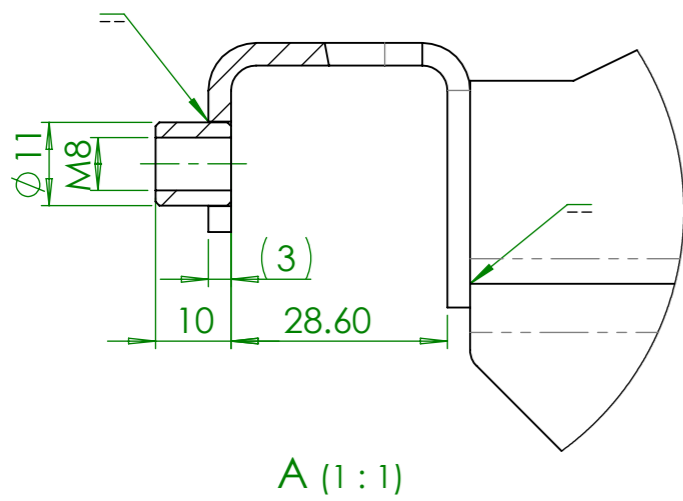
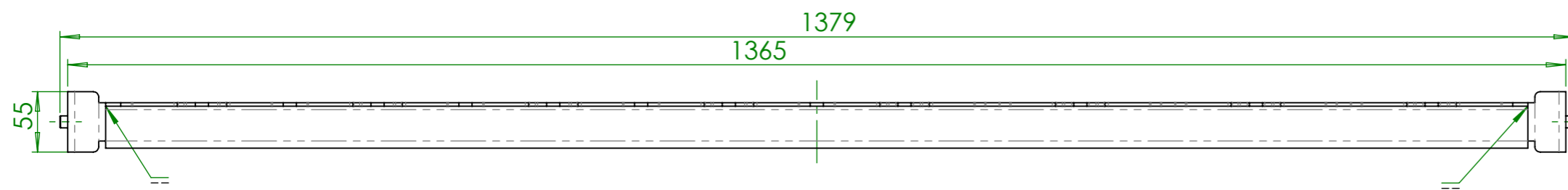
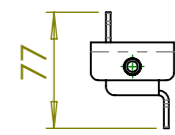
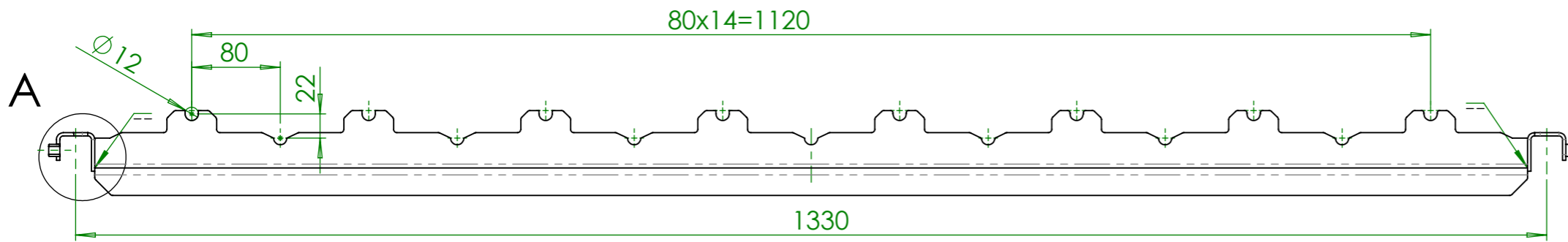

Menge: 2xStück

POS.	BENENNUNG	BESCHREIBUNG	MENGE
1	ZMOP-109-1	Spiesshalter	1
2	ZMOP-124-1	Lasche für Spiesshalter	1
3	ZCxx-124-1	Lasche für Spiesshalter - Spiegelbild	1
4	Gewindemuffe M8x10		2

Verwendungsbereich 750x77x55	Toleranz nach DIN ISO 2768-mK	Oberflächen DIN ISO 1302	Maßstab: 1:5 Werkstoff 1.4301 AISI 304	Gewicht: 3.23 kg
Name	Datum	Etagere Grill		
Bearb. M.B.	07/06/2019			
HEIDEBRENNER		ZMOP Spiesshalter	A3	

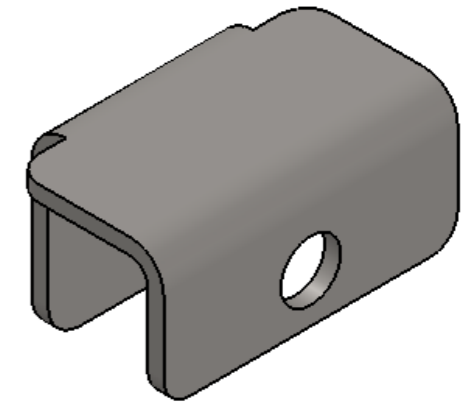
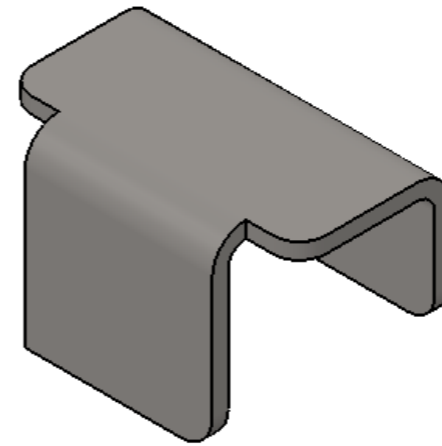
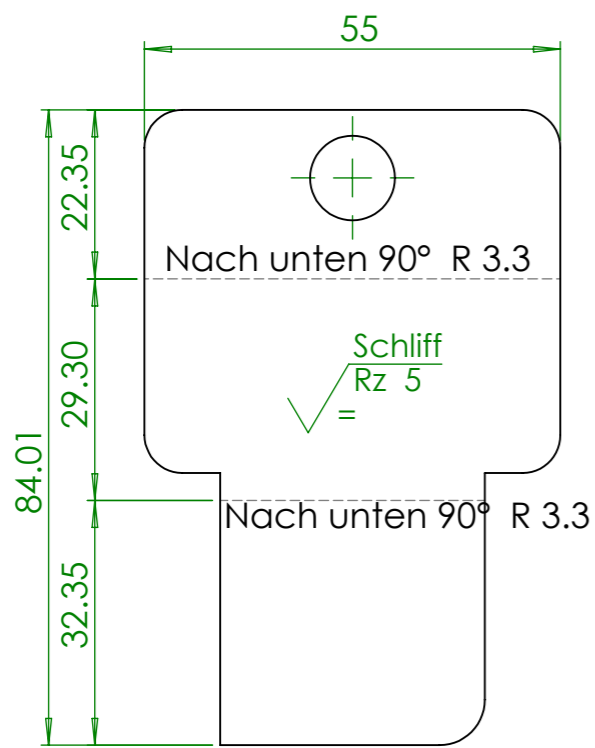
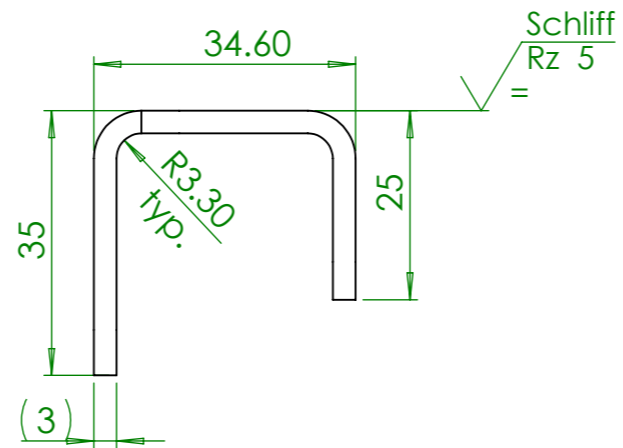
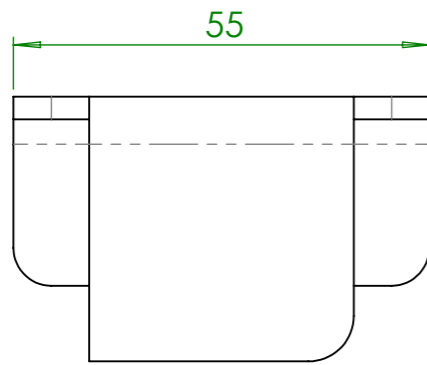

Menge: 1xStück
Gespiegelt - Menge: 1xStück

Verwendungsbereich 55x35x35	Toleranz nach DIN ISO 2768-mK	Oberflächen DIN ISO 1302	Maßstab: 1:1	Gewicht: 0.09 kg
			Werkstoff 1.4301 AISI 304	
Name	Datum	Etagere Grill		
Bearb. M.B.	07/06/2019			
HEIDEBRENNER		ZMOP Spiesshalter ZCxx-124-1 Lasche für Spiesshalter	A3	