

Verwendungsbereich 1070x900x1000	Toleranz nach DIN ISO 2768-mK	Oberflächen DIN ISO 1302	Maßstab: 1:16	Gewicht: 227 kg
			Werkstoff 1.4301	
Name	Datum		<b>Gas Lavastein-Grill ÄTNA</b>	
Bearb. M.B.	14.07.2020			
<b>HEIDEBRENNER</b>		<b>GMKC</b>		A3

Artikel Nr.	P [kW]	Pges [kW]	Volumenstrom V [m3/h]	Gasanschluß [Zoll]	Länge Verbrauchsleitung [m] delta p=0.6mBar
GMKC	3x12,8	38,4	4,07	3/4"	6

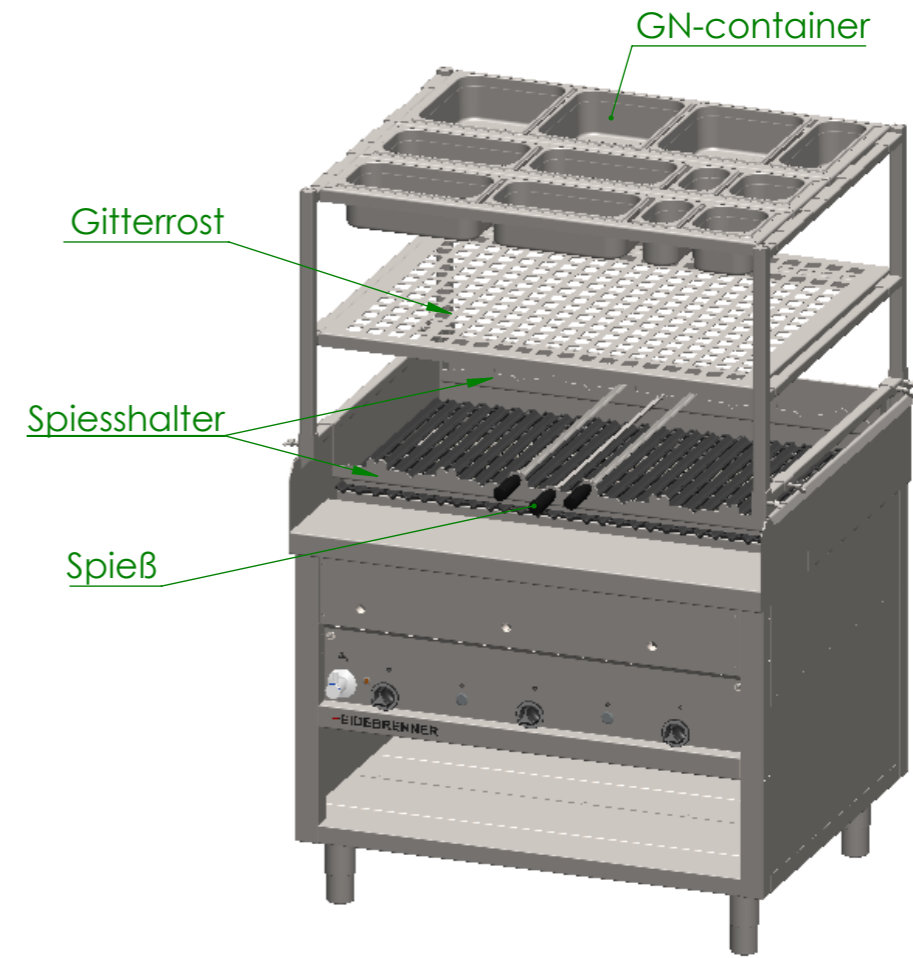
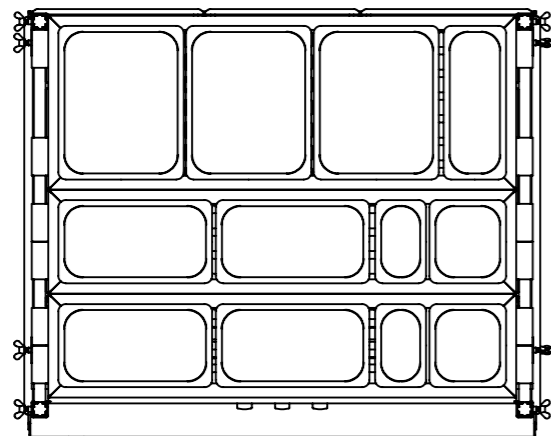
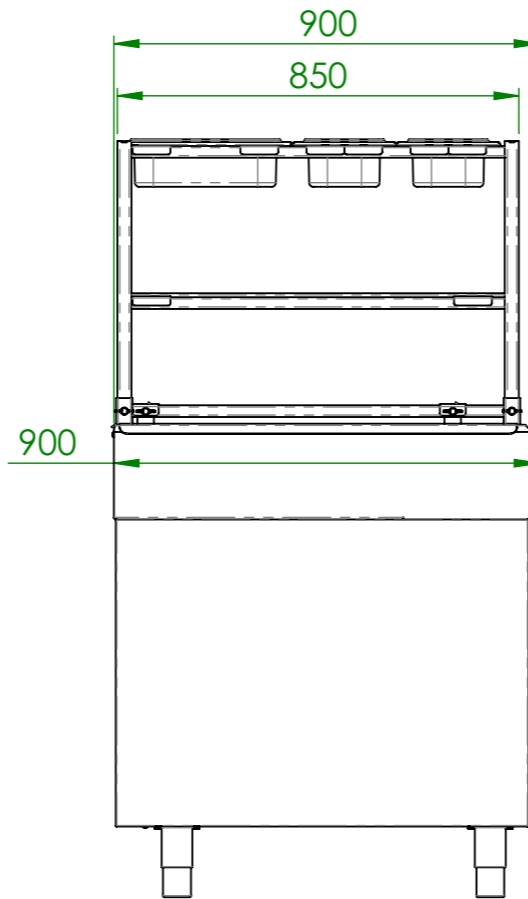
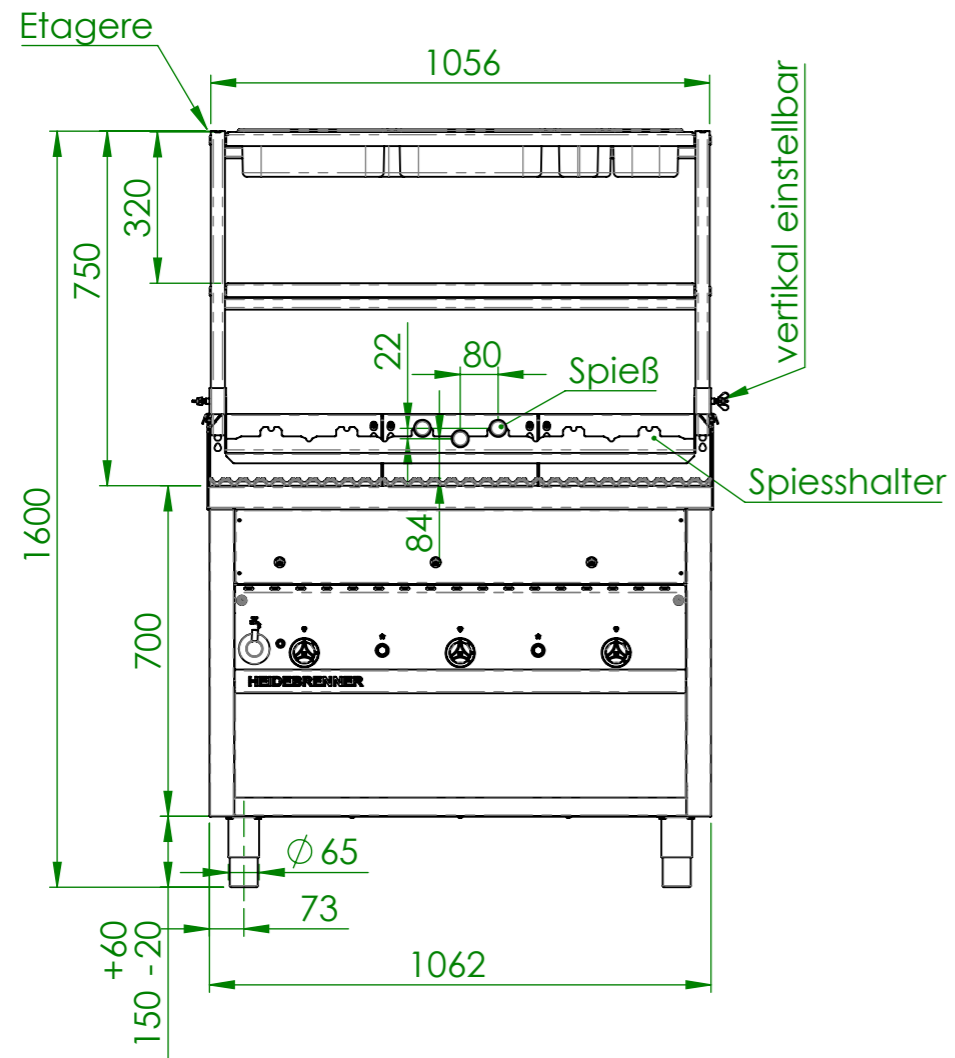

Verwendungsbereich 1070x900x1600	Toleranz nach DIN ISO 2768-mK	Oberflächen DIN ISO 1302	Maßstab: 1:16	Gewicht: 273 kg
			Werkstoff 1.4301	
Name	Datum	<b>Gas Lavastein-Grill ÄTNA</b>		
Bearb. M.B.	14.07.2020			
<b>HEIDEBRENNER</b>		<b>GMKC</b>		A3