

Gestell

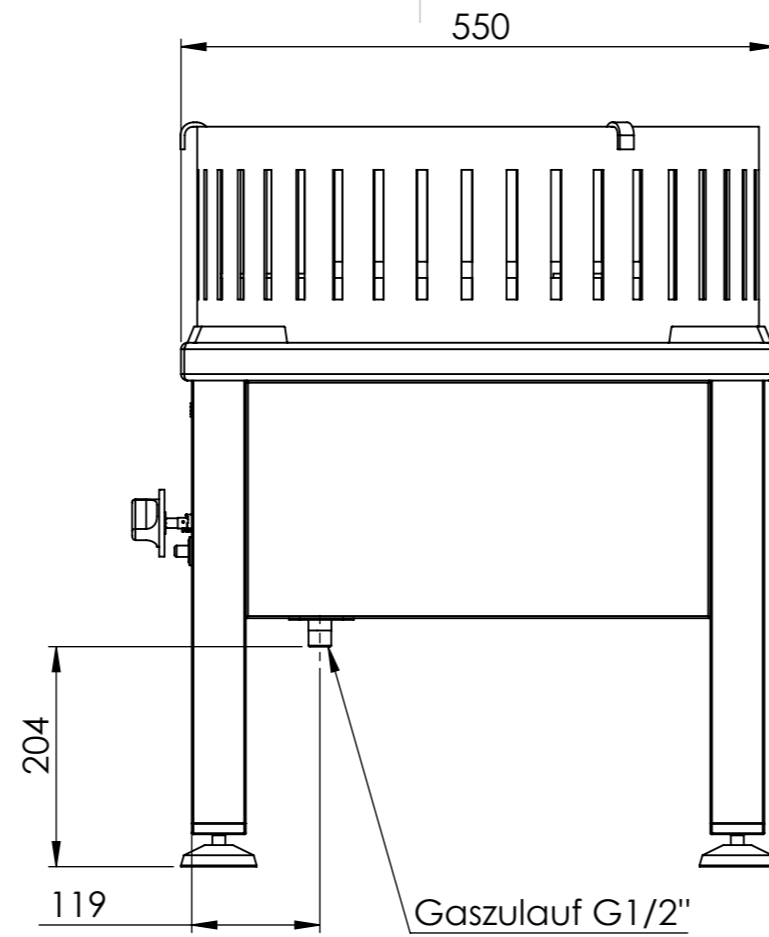

Gaszulauf G1/2"

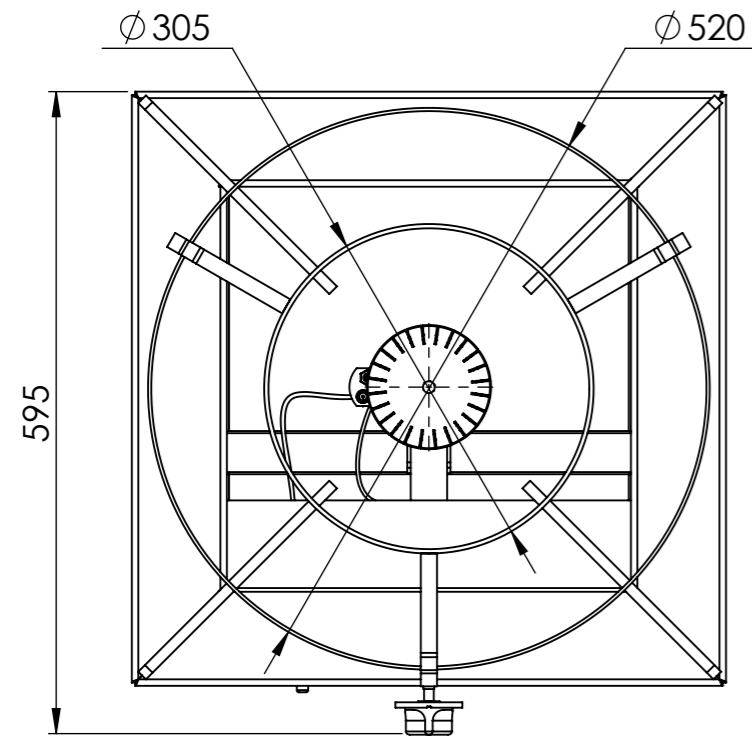
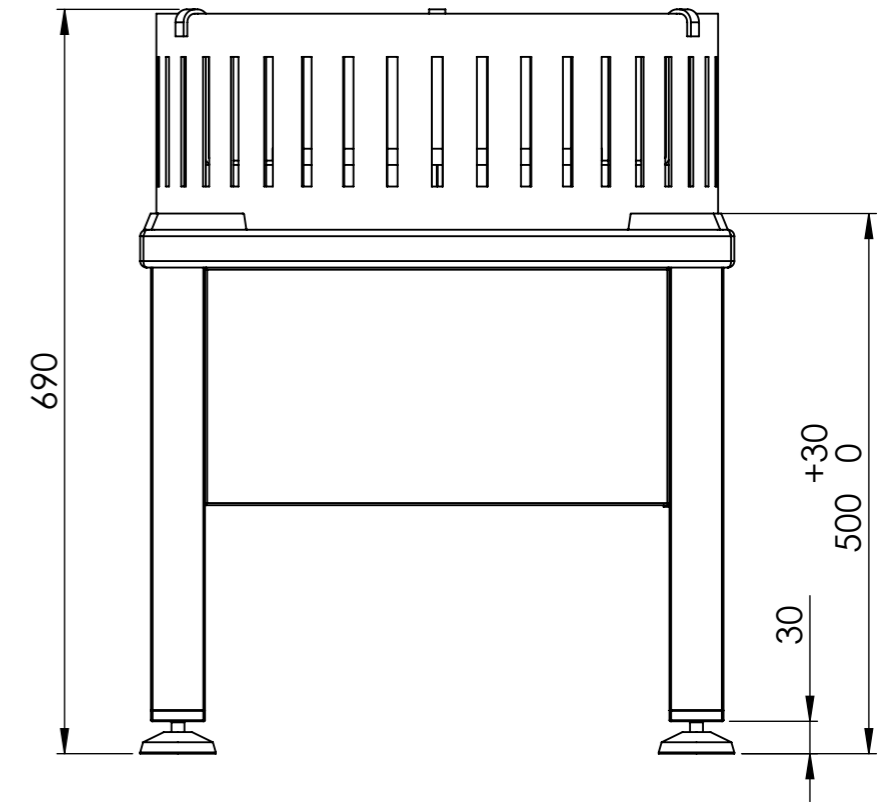

Piezozünder

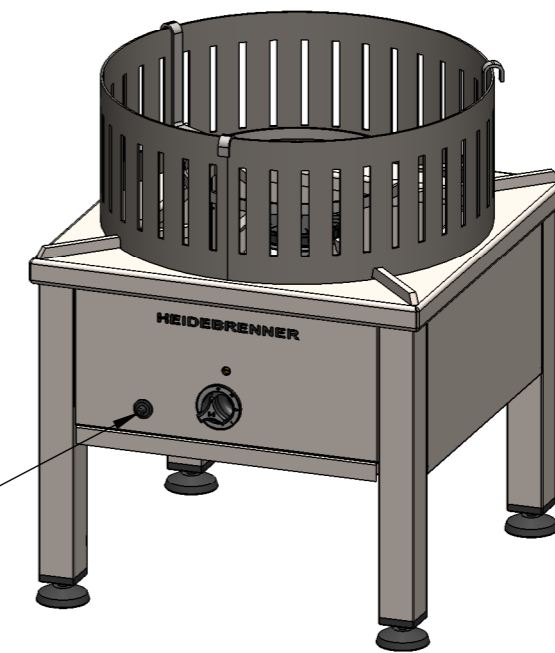

Artikel Nr.	HZ	Gestell	P _r Ges. [kW]	V _s 3 [m ³ /h]	Δ _p [mBar]	max. Länge Verbrauchslleitung, [m]	Gaszulauf [Zoll]
GOHCE	1	1.4301/EN-GJL-200	9,3	1	0,4	20	1/2
GOHCF	1	1.4301	9,3	1	0,4	20	1/2

Verwendungsbereich 550x550x500	Toleranz nach DIN ISO 2768-mK	Oberflächen DIN ISO 1302	Maßstab: 1:7	Gewicht: 43kg
Name	Datum	Gas Hockerkocher		
Bearb. A.V.	30.03.2017			
HEIDEBRENNER		GOHCF	A3	