

6x Gasventil
6x Taster für elektrische Zündung

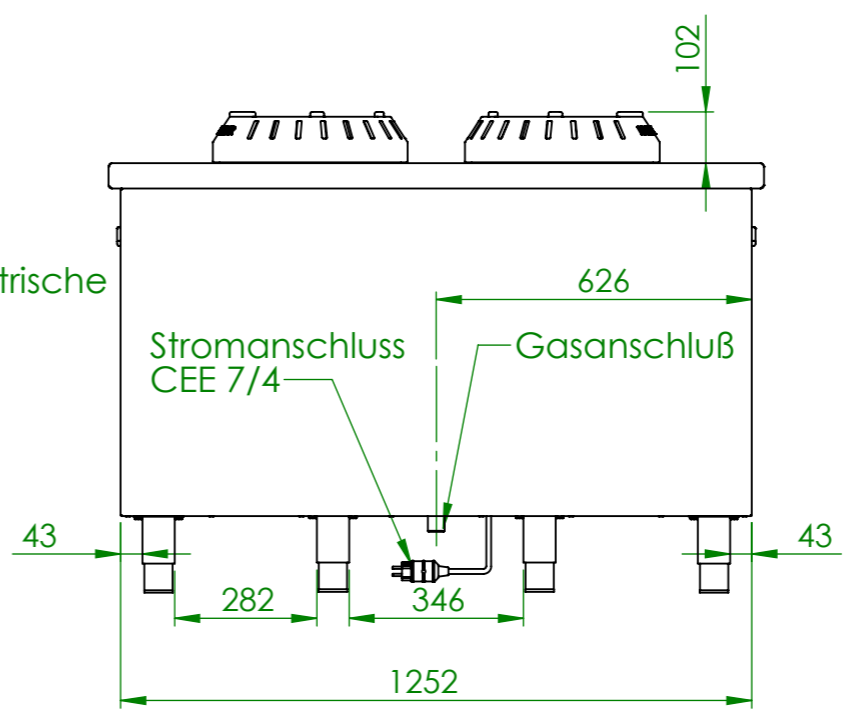

Stromanschluss CEE 7/4
Gasanschluß

	GGMBF	GGMCF
P[kW]	8	12
Gas Wok-Range	Wärmeabgabe [W]	
Sensible Wärme	8400	12600
Latente Wärme	5040	7560
Dampfabgaben	8904	13356

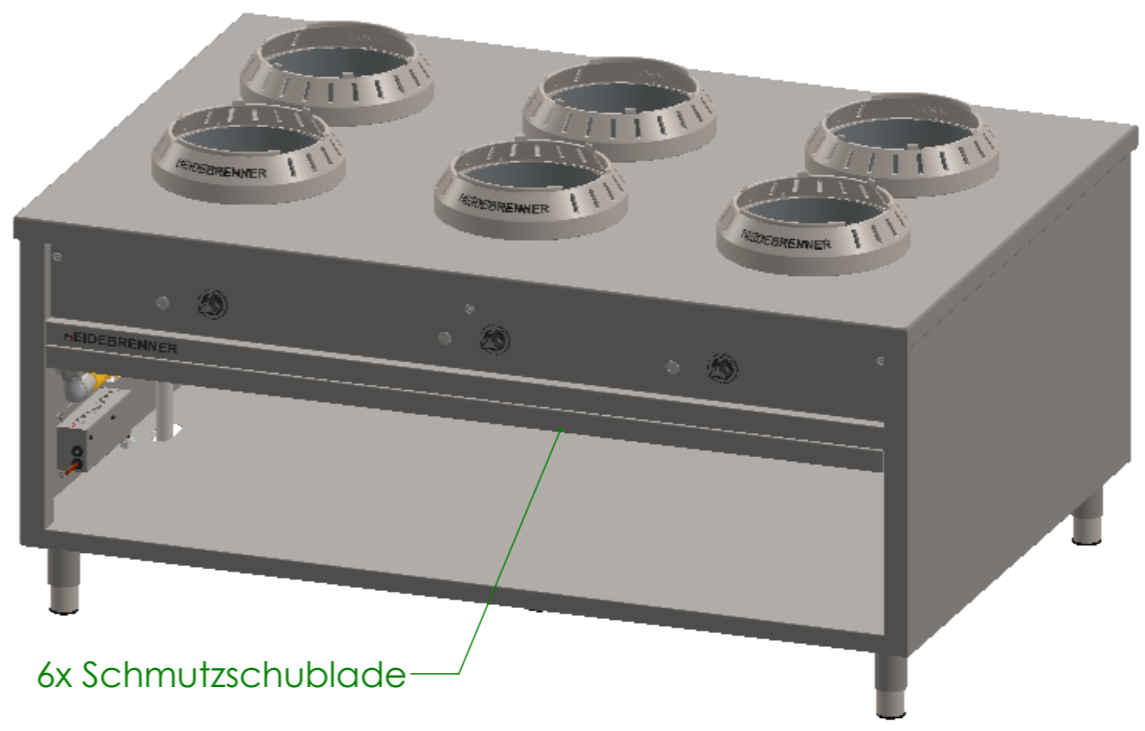
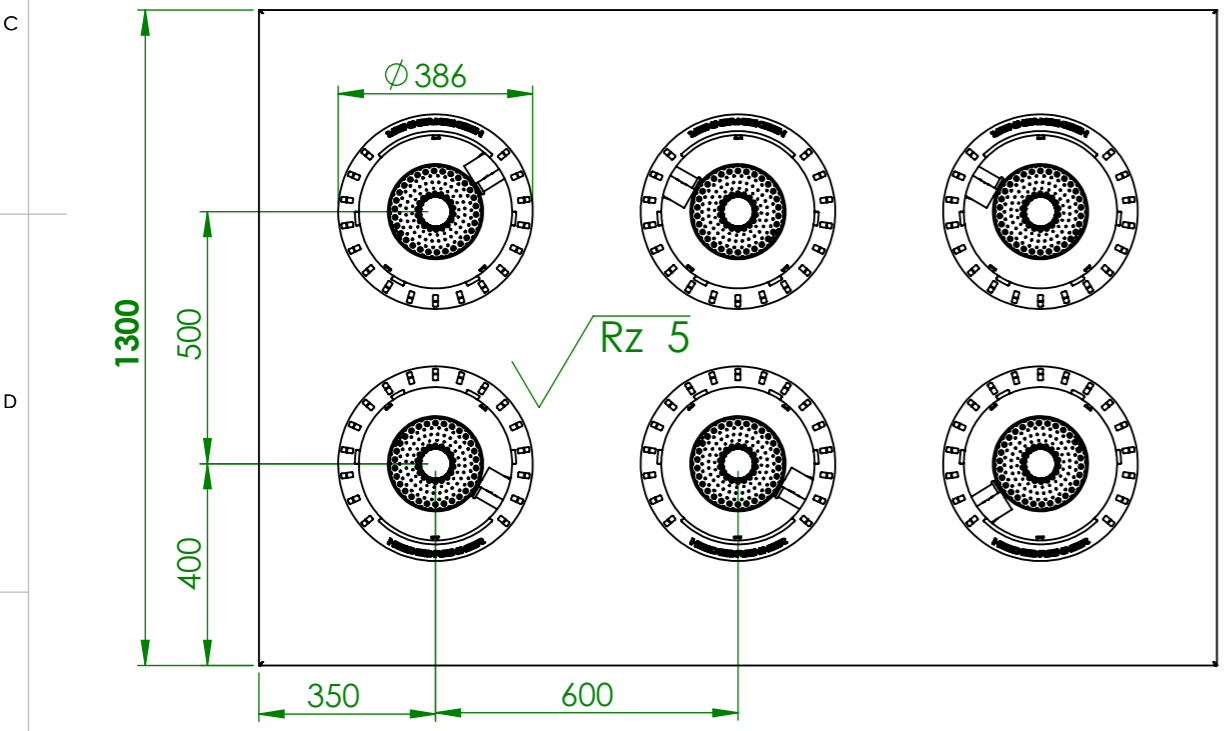

6x Schmutzschublade

Art.Nr	HZ	P[kW]	Pges [kW]	Volumenstrom V[m3/h]	Gasanschluß [Zoll]	Länge Verbrauchsleitung [m] delta p=0.6mBar	Gas type	Stromanschluss
GGMBF	6	8	48	5,076	1	13	12H	CEE 7/4, 1L+N+PE, 6A P=20V
GGMCF		12	72	7,62	1 1/4	>20		

Verwendungsbereich 1900x850x1300	Toleranz nach DIN ISO 2768-mK	Oberflächen DIN ISO 1302	Maßstab: 1:15 Werkstoff 1.4301 AISI 304	Gewicht: 349 kg
Name	Datum	Gas Wok-Range Insel "HENAN"		
Bearb. M.G.	12.08.2020			
HEIDEBRENNER		GGMxF		A3