

Art.Nr	KochStellen-Brenner	WarzenBrenner	P[kW]	Pges [kW]	Volumenstrom V[m3/h]	Gasanschluß [Zoll]	Länge Verbrauchsleitung [m] delta p=0.6mBar
GLHGD	8	-	5,8	46,4	4,94	1	13
GLHND	-	8	8,7	69,6	7,4		6

Verwendungsbereich 1450x750x850	Toleranz nach DIN ISO 2768-mK	Oberflächen DIN ISO 1302	Maßstab: 1:12	Gewicht: 170 kg
Name		Datum		
Bearb. M.G.		16.12.2020		
Werkstoff 1.4301 AISI 304		Gas-Range „TEXAS“		
HEIDEBRENNER		GLH_D		A3

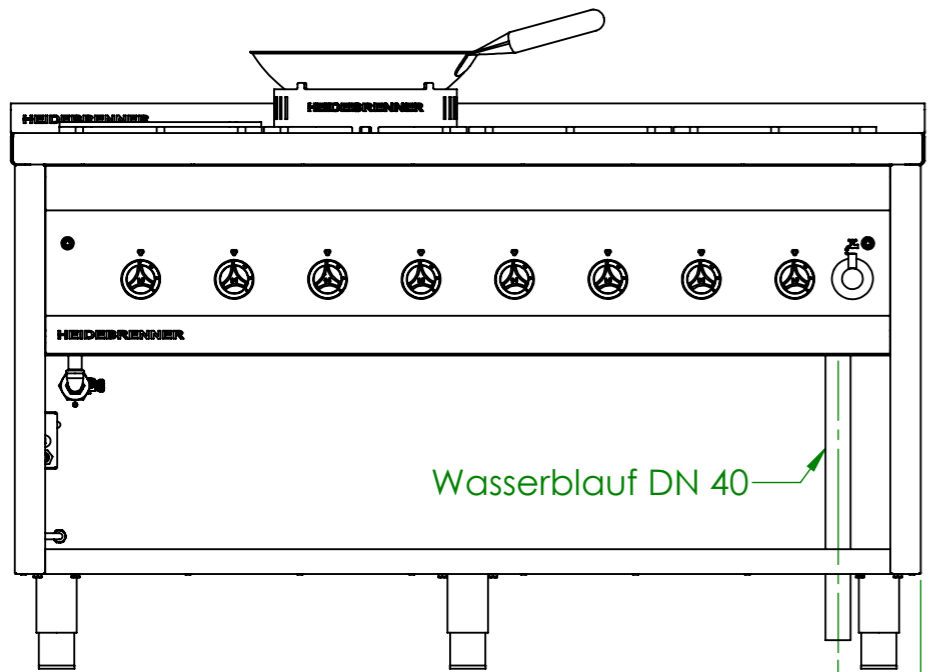

Wasserlauf DN 40

131

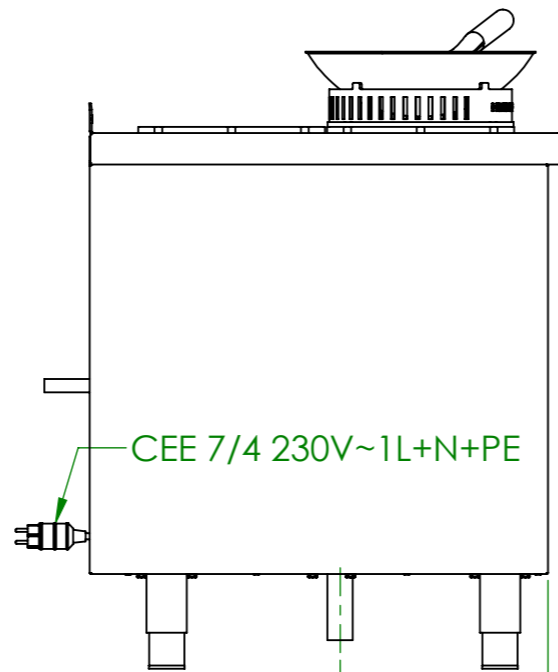

CEE 7/4 230V~1L+N+PE

330

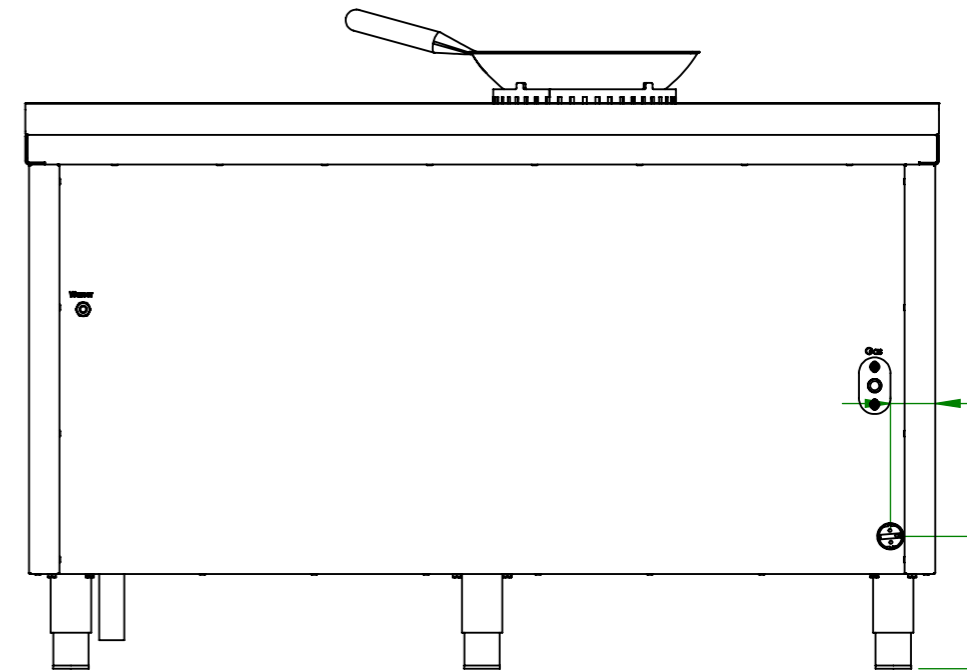

71

210

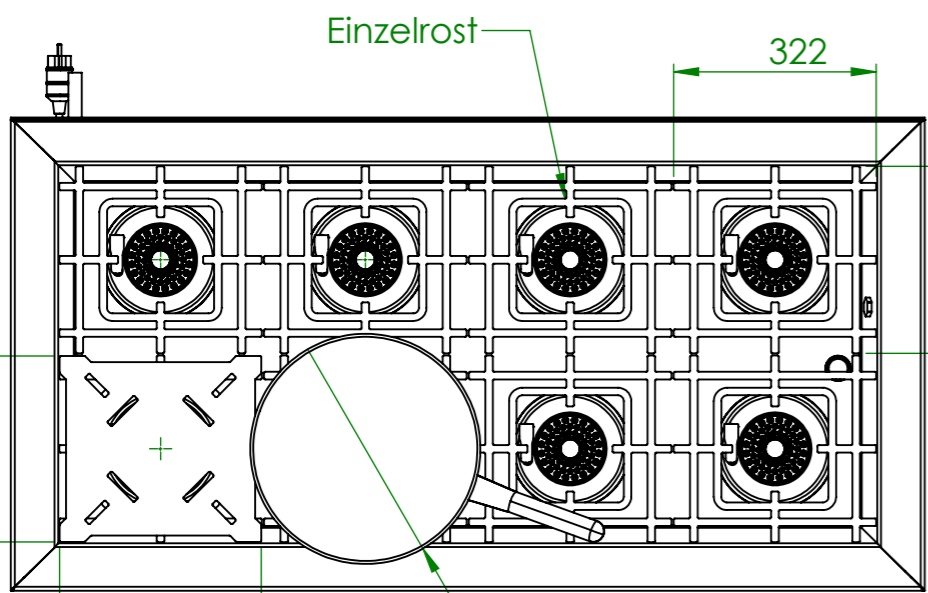

Einzelrost

322

297

320

Ø360

Einzelrost
Fortkochplatte 320x295
t=8mm

Wok-Pfanne Ø360

Wokring

Elektr. Zündgruppe

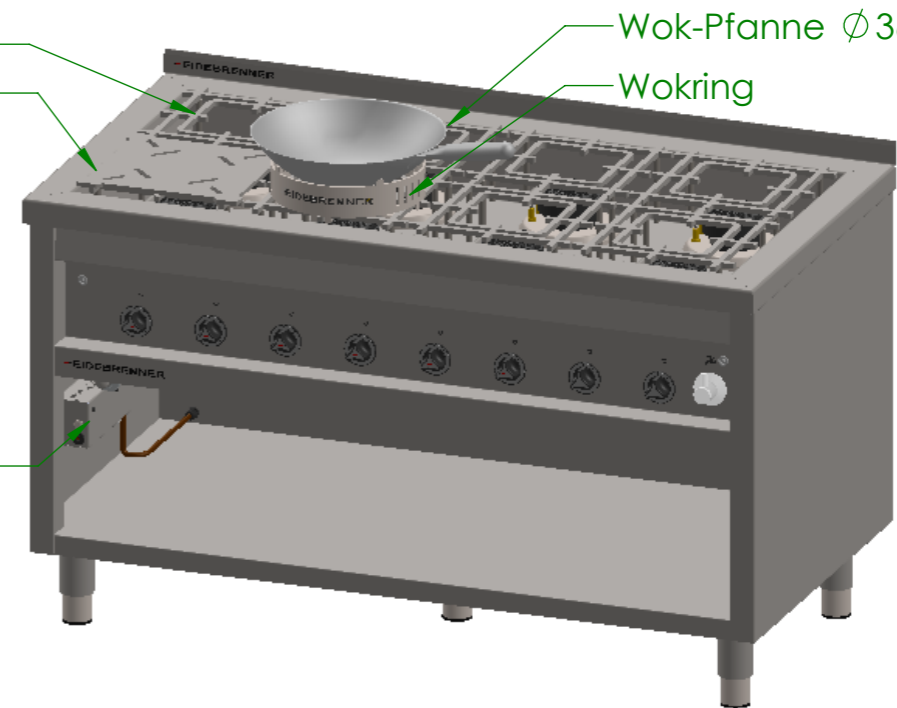

Verwendungsbereich 1450x750x850	Toleranz nach DIN ISO 2768-mK	Oberflächen DIN ISO 1302	Maßstab: 1:12 Werkstoff 1.4301 AISI 304	Gewicht: 181,5 kg
Name	Datum	Gas-Range „TEXAS“		
Bearb. M.G.	16.12.2020			
HEIDEBRENNER		GLH_D + Zubehör		A3