

Art. Nr	HZ	P[kW]	Wasser	Abwasser	Strom
EFDBD	2	2 x 9	G 1/2"	DN 50	CEE 32 A, 400V~ 3L+N+PE, 6h
EFDDD	4	4 x 4,5			

Verwendungsbereich 1373x650x350	Toleranz nach DIN ISO 2768-mK	Oberflächen DIN ISO 1302	Maßstab: 1:10	Gewicht: 120 kg
Name		Datum		
Bearb. G.N.		17.03.2020		
Werkstoff 1.4301 AISI 304		Elektro Lava/Wasser Grill BLES1		
HEIDEBRENNER		EFD_D - Tischgerät		A3

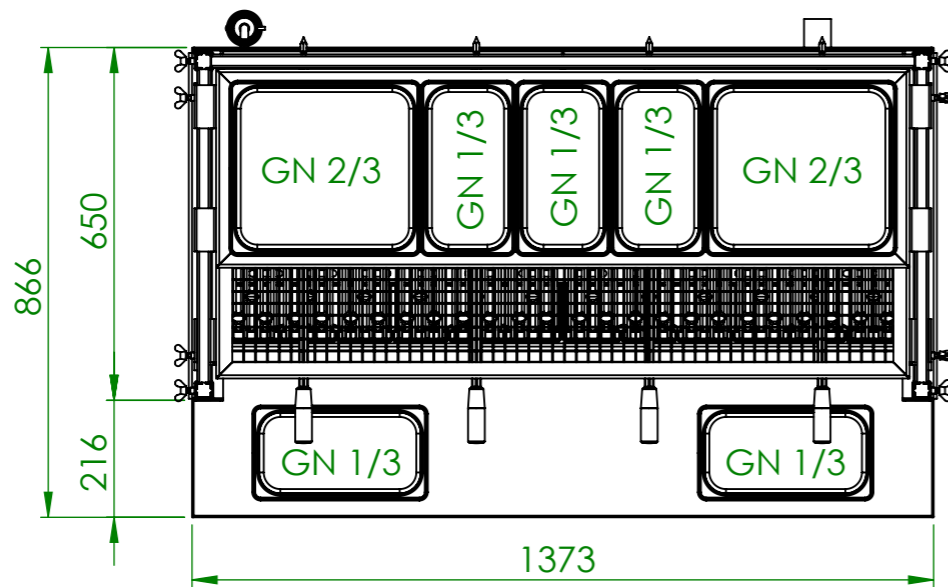

- ZQDP - 325 GN Halter
- ZQTP - 1/1 Gitterrost
- ZQSP - Etagere
- ZMQP - Spiesshalter
- Spieß
- ZQXP - GN Halter

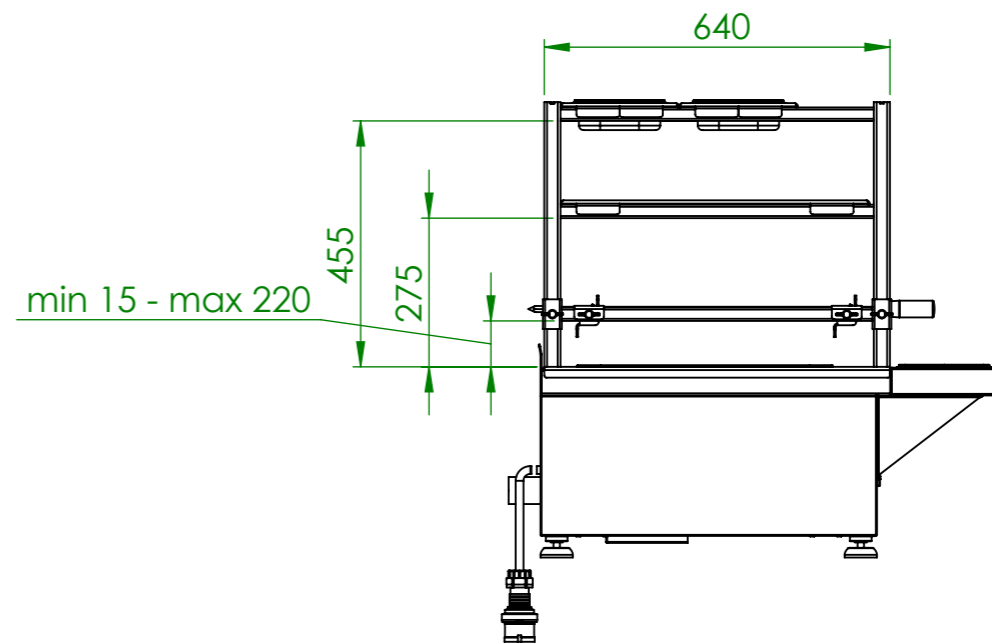
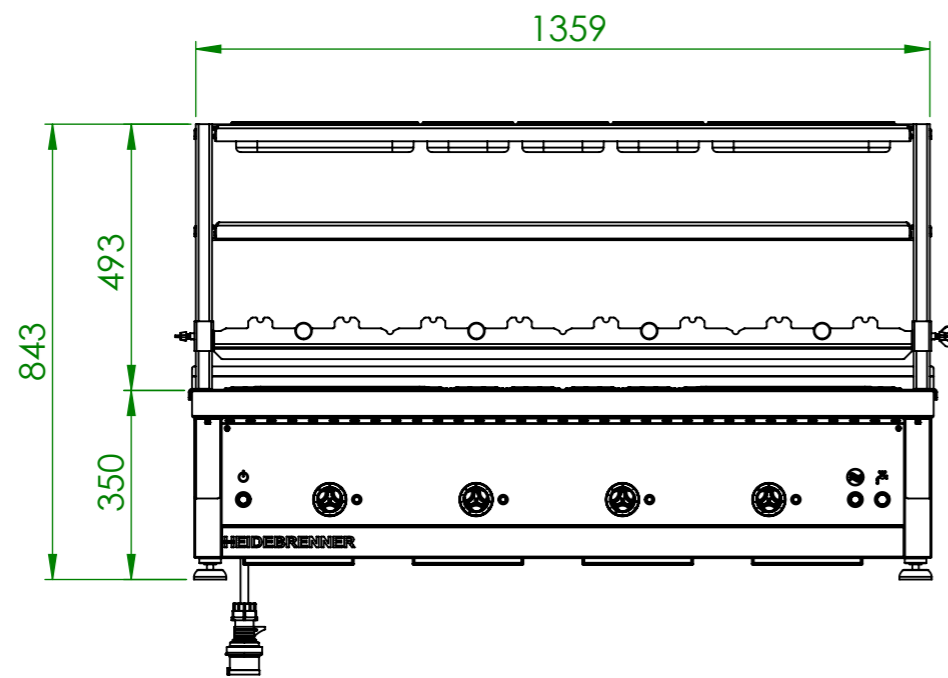
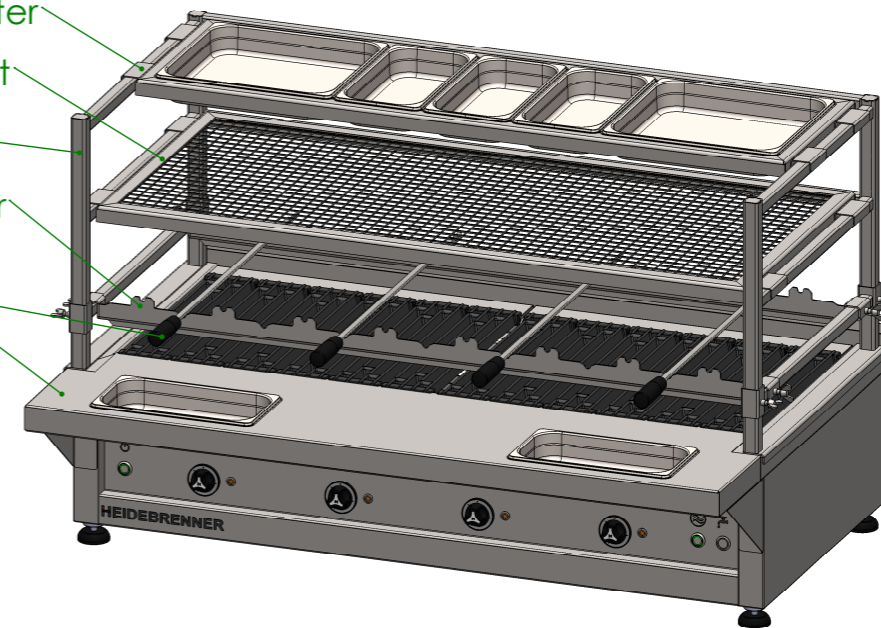

Verwendungsbereich 1373x866x843	Toleranz nach DIN ISO 2768-mK	Oberflächen DIN ISO 1302	Maßstab: 1:14	Gewicht: 195 kg
			Werkstoff 1.4301 AISI 304	
Name	Datum	Elektro Lava/Wasser Grill BLES1		
Bearb. G.N.	01.04.2020			
HEIDEBRENNER		EFD_D + ETAGERE		A3